

OWNER'S MANUAL

PRINT MASTER 700 SERIES PRINTER CONTROLLERS

706A
706C
708C
710C
706D
708D
706E
708E
710E
708F
710F

BayTech publication #U140E045-05

Dear Customer,

Thank you for selecting a BayTech Print Master printer controller.

The data provided in this Owner's Manual explains the various ways you can operate your unit and configure it to your own computer system. We suggest that you read this manual carefully before attempting to install Print Master and that you place special emphasis on correct cabling and configuration. If you have any problems with your installation, please contact a BayTech applications engineer for assistance.

BayTech also manufactures data communications devices that provide port sharing and expansion, networking, port contention, buffered and non-buffered printer sharing, and multiplexing. If you would like information on any of these models, please contact BayTech Customer Service.

We welcome any comments you may have about our products. And we hope that you will continue to look to BayTech for your data communications needs.

The information contained in this document is subject to change without notice.

Copyright 1993 by Bay Technical Associates, Inc.

IBM PC, IBM PC/AT, IBM PC/XT and IBM PS/2 are products of International Business Machines Corporation.

Hewlett-Packard LaserJet is a product of the Hewlett-Packard Company.

Wordperfect is a product of Wordperfect, Inc.

WordStar is a registered trademark of MicroPro International Corp.

Windows is a registered trademark of Microsoft Corp.

Print Master is a registered trademark of Bay Technical Associates, Inc.

TABLE OF CONTENTS

- 1 GENERAL INFORMATION..... 1
- 2 SPECIFICATIONS 3
- 3 QUICK REFERENCE 6
- 4 INSTALLATION 10
 - 4.1 UNPACKING..... 10
 - 4.2 SOFTWARE UTILITY DISKETTE..... 10
 - 4.3 POWER 12
 - 4.4 FACTORY DEFAULTS 12
 - 4.5 PC SET-UP 13
- 5 CABLING 15
 - 5.1 PARALLEL PORTS..... 15
 - 5.2 SERIAL PORTS..... 16
 - 5.3 PRINT MASTER MODELS 706C, 708C AND 710C WITH RJ-45 MODULAR CONNECTORS .. 19
- 6 OPERATION..... 20
 - 6.1 USER-PROGRAMMABLE CONFIGURATIONS.. 20
 - 6.1.1 THE PORT LOGICAL NAME 20
 - 6.1.2 THE NUMBER OF PRINTERS/THE PORT ASSIGNMENT..... 21
 - 6.1.3 THE PRINTER SELECT CODE 22
 - 6.1.4 THE PRINTER SELECT MODE..... 22
 - 6.1.5 THE SERIAL PORT CONFIGURATION ... 23
 - 6.1.6 THE INPUT INACTIVITY TIMEOUT..... 23
 - 6.1.7 THE FORM FEED MODE 23
 - 6.1.8 THE HEADER PAGE MESSAGE..... 24

6.2	PRINTER SHARING OPERATING PROCEDURE	24
6.2.1	SHARING A SINGLE PRINTER.....	25
6.2.2	SPECIFIED SHARING OF MULTIPLE PRINTERS	26
6.2.3	CONTENDING FOR MULTIPLE PRINTERS	27
6.2.4	BUFFERING OF PRINT DATA	28
6.2.5	BEGINNING AND ENDING A PRINT JOB	28
6.2.6	BUFFER CLEARING	30
6.2.7	MINIMUM SIZE PRINT JOB.....	30
6.2.8	PORT SELECTION METHODS	31
6.2.9	FULL DUPLEX COMMUNICATION	32
6.2.10	PLOTTER SHARING HINTS.....	32
6.3	LED INDICATORS	33
6.4	DATA FLOW CONTROL.....	34
6.4.1	HARDWARE HANDSHAKING	34
6.4.2	XON/XOFF HANDSHAKING	36
6.4.3	HP 3000 OPTION.....	37
7	CONFIGURATION	38
7.1	MODELS 706A AND 708A - CONFIGURATION PROCEDURE	38
7.1.1	MODELS 706A AND 708A - MAIN CONFIGURATION MENU	40
7.1.2	MODELS 706A AND 708A - STATUS.....	41
7.1.3	MODELS 706A AND 708A - CHANGE LOGICAL NAME.....	42
7.1.4	MODELS 706A AND 708A - SET INPUT INACTIVITY TIMEOUT.....	43
7.1.5	MODELS 706A AND 708A - SET NUMBER OF PRINTERS.....	44

7.1.6	MODELS 706A AND 708A - PROGRAM PRINTER SELECT CODE	45
7.1.7	MODELS 706A AND 708A - SET PRINTER SELECT MODE	46
7.1.8	MODELS 706A AND 708A - SET FORM FEED MODE	46
7.1.9	MODELS 706A AND 708A - PROGRAM HEADER PAGE MESSAGE	47
7.1.10	MODELS 706A AND 708A - EXIT	47
7.2	ALL 700C MODELS - CONFIGURATION PROCEDURE	48
7.2.1	ALL 700C MODELS - MAIN CONFIGURATION MENU	50
7.2.2	ALL 700C MODELS - STATUS	51
7.2.3	ALL 700C MODELS - SET SERIAL PORT CONFIGURATION	52
7.2.4	ALL 700C MODELS - SET INPUT INACTIVITY TIMEOUT	55
7.2.5	ALL 700C MODELS - SET NUMBER OF PRINTERS	56
7.2.6	ALL 700C MODELS - PROGRAM PRINTER SELECT CODE	57
7.2.7	ALL 700C MODELS - SET PRINTER SELECT MODE	58
7.2.8	ALL 700C MODELS - SET FORM FEED MODE	58
7.2.9	ALL 700C MODELS - PROGRAM HEADER PAGE MESSAGE	59
7.2.10	ALL 700C MODELS - EXIT	59

7.3	ALL 700D, 700E, 700F MODELS - CONFIGURATION PROCEDURE	60
7.3.1	ALL 700D, 700E, 700F MODELS - MAIN CONFIGURATION MENU	62
7.3.2	ALL 700D, 700E, 700F MODELS - STATUS	63
7.3.3	ALL 700D, 700E, 700F MODELS -SET SERIAL PORT CONFIGURATION.....	64
7.3.4	ALL 700D, 700E, 700F MODELS -CHANGE PORT LOGICAL NAME	67
7.3.5	ALL 700D, 700E, 700F MODELS - SET PORT ASSIGNMENT	68
7.3.6	ALL 700D, 700E, 700F MODELS -SET INPUT INACTIVITY TIMEOUT	70
7.3.7	ALL 700D, 700E, 700F MODELS -PROGRAM PRINTER SELECT CODE....	71
7.3.8	ALL 700D, 700E, 700F MODELS - SET PRINTER SELECT MODE	72
7.3.9	ALL 700D, 700E, 700F MODELS - SET FORM FEED MODE.....	72
7.3.10	ALL 700D, 700E, 700F MODELS - PROGRAM HEADER PAGE MESSAGE ..	73
7.3.11	ALL 700D, 700E, 700F MODELS - EXIT ..	73
8	MAINTENANCE.....	74
9	REPACKING FOR SHIPPING	74
10	TECHNICAL SUPPORT	75
11	FEDERAL COMMUNICATIONS COMMISSION RADIO FREQUENCY INTERFACE STATEMENT	77

APPENDIX A

RECOMMENDED CABLING 78

A.1 BETWEEN IBM PC, IBM XT, IBM PS/2
AND PRINT MASTER (DB-25) 78

A.2 BETWEEN IBM AT AND PRINT MASTER
(DE-9)..... 80

A.3 BETWEEN PRINT MASTER AND
HEWLETT PACKARD LASERJET 82

A.4 BETWEEN PRINT MASTER AND
ANY CENTRONICS PRINTER 83

A.5 700C MODELS - MODULAR CABLING..... 84

APPENDIX B

OPTION 19 - CASCADE FEATURE FOR MODELS 710C,
710E, 710F 86

B.1 OPTION 19 - CONFIGURATION 87

B.1.1 OPTION 19 - MAIN CONFIGURATION
MENU 88

B.1.2 OPTION 19 - CONFIGURATION STATUS 89

B.1.3 OPTION 19 - SET UNIT ID NUMBER 90

B.2 OPTION 19 - CABLING 91

B.3 OPTION 19 - SHARING OF PRINTERS..... 91

APPENDIX C

TROUBLESHOOTING..... 93

APPENDIX D

INDEX..... 102

1 GENERAL INFORMATION

The BayTech 700 Series Print Master is a flexible, intelligent device that connects between your computers and peripherals allowing the computers to share the peripherals, including expensive plotters and laser printers. All models come in a self-contained desk-top unit or with a rack mount.

Print Master comes standard with a 1 MB buffer which is optionally available up to 2 MB. The built-in buffer saves valuable computer time by spooling data until the printer or plotter can receive it, keeping the computers working full time instead of waiting.

Print Master models are available with full duplex EIA-232 serial ports and/or Centronics compatible parallel ports depending upon the model purchased. The available serial/parallel port combination are listed below by model.

Model 706A has six parallel ports.

Model 708A has six parallel ports.

Model 706C has six serial ports.

Model 708C has eight serial ports.

Model 710C has ten serial ports.

Model 706D has four parallel and two serial ports.

Model 708D has six parallel and two serial ports.

Model 706E has four serial and two parallel ports.

Model 708E has six serial and two parallel ports.

Model 710E has eight serial and two parallel ports.

Model 708F has four serial and four parallel ports.

Model 710F has six serial and four parallel ports.

On models with combination serial and parallel ports, you may set up Print Master with parallel or serial in and parallel or serial out. Print Master internally converts data from serial-to-parallel or parallel-to-serial. Ports are user-configurable as computer ports or printer ports.

In addition to port assignment, you may program the following features to meet the need of your application: the individual serial port configuration (baud rate, word size, stop bits, parity, and XON/XOFF), the Port Logical Names, the Input Inactivity Timeout, the Printer Select Code, the Printer Select Mode, the Form Feed Mode, and the Header Page Message. Programming of these features is easily accomplished via the menu-driven configuration mode, and all changes are saved in non-volatile memory.

NOTE: Users of IBM compatible computers may utilize the BayTech Print Master Support Software Diskette supplied with the unit. Refer to *Section 4.2* for instructions.

A typical application using Print Master would allow various computers (e.g., PCs, main frames, mini computers, etc.) to share printers and/or plotters. For example, *Figure 1* below shows seven PCs sharing a single HP LaserJet IIISi printer. This application would allow all the PCs to send print jobs to the printer simultaneously.

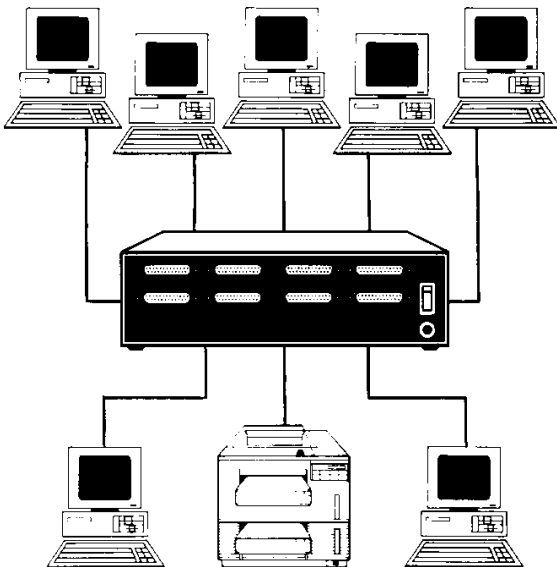

This application demonstrates just one on the many Print Master configuration possibilities. Print Master ports are programmable as computer or printer ports

Figure 1

2. SPECIFICATIONS

INTERFACE:

Serial ports: Asynchronous EIA-232C (CCITT V.24),
-12v mark, +12v space. Full duplex
communication.

Parallel ports: Centronics protocol.

TRANSMISSION: Serial ports - asynchronous; full duplex
communication;

Parallel ports - maximum 30,000 characters per
second on the 706A and 708A. Up to 5000
characters per second on all other models.

STANDARD FACTORY-SET POWER-UP DEFAULT CONFIGURATION:

Serial ports:

Baud rate: 9600.

Word size: 8.

Stop bits: 1.

Parity: None.

XON/XOFF: Off.

Logical name: Device A to J.

Input inactivity timeout: 20 seconds.

Port assignment: Port 1 - printer port.

All other ports - computer ports.

Printer Select Code: \$PRINTER.

Printer Select Mode: 2 (Anytime while printing).

Form feed mode: 1 (no form feed).

Header Page Message: Off. "This print job is for:".

USER-PROGRAMMABLE CONFIGURATION:

Reconfigurable in menu-driven mode through configuration port. Saved in non-volatile memory to become the new power-up default configuration.

Serial ports:

Baud rate: 110, 135, 300, 600, 1200, 2400, 4800, 9600, 19200. Other rates optional.

Word size: 5, 6, 7 or 8 bits.

Parity: Even, odd or none.

Stop bits: 1, 1 1/2 or 2.

XON/XOFF: On or off.

Port logical name: 16 characters.

Input inactivity timeout: 1 to 200 seconds or no timeout.

Port assignment: Any port user-set as computer or printer port with a minimum of one printer port and one computer port.

Printer Select Code: 1 to 8 ASCII characters.

Printer Select Mode:

Mode 1 = printer selection at beginning of printing;

Mode 2 = printer selection any time while printing.

Form feed mode: Mode 1 = no form feed;

Mode 2 = at beginning of printing;

Mode 3 = at end of printing;

Mode 4 = at beginning and end of printing.

Header Page Message: 80 characters.

MINIMUM SIZE PRINT JOB: 3 characters.

INTERNAL BUFFER: 1 MB standard. All models available with 1.5 MB or 2 MB except the 706A and 708A. 706A and 708A models are available with 2 MB, 3 MB, or 4 MB.

POWER: 115 VAC, 50/60 Hz., .3A.
Optional 230 VAC, 50/60 Hz., .2A.

ENVIRONMENT: 0 degrees to 55 degrees C temperature;
5% to 95% humidity.

DIMENSIONS: 10 1/8w x 8d x 3h inches.

WEIGHT: 6 pounds.

INDICATORS: 1 green power LED; 6, 8 or 10 red,
port-activity LEDs.

CONNECTORS: Shielded on all ports.
Serial ports - DB-25 female DCE connectors.
Parallel ports - DB-25 female connectors.
RJ-45 connectors available on the 706C, 708C, and
710C.

HANDSHAKING: Parallel ports - Busy (pin 11).
Serial ports - CTS/DTR and selectable XON/XOFF.

MOUNTING: Desk-top; rack-mount optional.

WARRANTY: One year parts and labor.

3 QUICK REFERENCE

This section provides basic set up instructions for those knowledgeable in computer equipment installation. We will refer to specific sections in this manual for more in-depth instructions on installation operation, and configuration. Please review the following procedure:

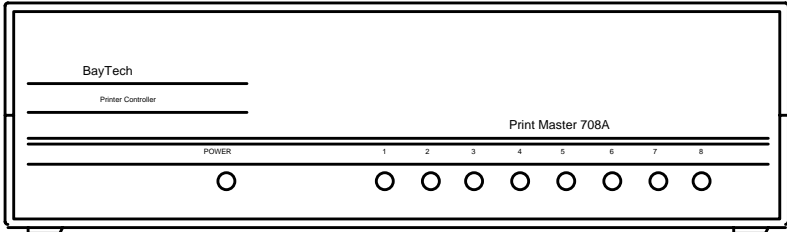
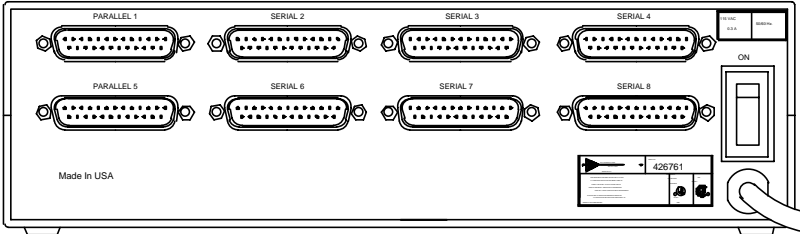
Step	Instructions
1	<p>Determine what model Print Master you are installing. The model number is written on the front panel as shown below for the model 708A.</p>  <p>Print Master Model 708A</p> <p>Identify which ports are serial and which are parallel. Ports are marked as serial or parallel on the back panel as shown below for the model 708E.</p>  <p>Print Master II Model 708E</p> <p>Determine what devices will connect to your Print Master and whether they will connect in serial or parallel. Typical devices include computers, printers, and plotters.</p>
2	<p>PORT DESIGNATION</p> <p>Determine which serial or parallel ports on Print Master will be assigned as computer or printer. Computers connect to ports assigned as computer. Printers and plotters</p>

Step	Instructions
	<p>connect to ports assigned as printer. All ports are flexible except as noted below (i.e., ports may be configured as computer or printer). The standard factory default power-up configuration follows:</p> <p>706A & 706C: Port 6 - computer port (host) * Port 1 - printer port * Ports 2 through 5 - computer ports</p> <p>706D & 706E: Port 6 - computer port (host) Port 1 - printer port Ports 2 through 5 - computer ports</p> <p>708A & 708C: Port 8 - computer port (host) * Port 1 - printer port * Ports 2 through 7 - computer ports</p> <p>708D, 708E, & 708F: Port 8 - computer port (host) Port 1 - printer port Ports 2 through 7 - computer ports</p> <p>710C: Port 10 - computer port (host) * Port 1 - printer port * Ports 2 through 9 - computer ports</p> <p>710E & 710F: Port 10 - computer port (host) Port 1 - printer port Ports 2 through 9 - computer ports</p> <p>If your application requires port assignments that are different from the factory default configuration, you must reconfigure your unit. Step 5 discusses configuration mode.</p> <p>NOTE: If your application requires sharing more than one printer or plotter, you will have to reconfigure the port assignment(s) of your unit.</p> <p>* Ports are fixed as computer or printer (i.e., cannot be changed).</p>
3	<p>SERIAL PORT CONFIGURATION</p> <p>NOTE: This step does not apply to the 706A and 708A models.</p> <p>The serial port configuration of your serial devices and Print Master must all match. Print Master's default configuration follows:</p> <p style="padding-left: 40px;">Baud Rate: 9600 bps Word Size: 8 bits Stop Bits: 1 bit Parity: None XON/XOFF: Off</p> <p>If you will be connecting any serial devices which communicate with serial parameters different than the default configuration, you must access configuration mode and make the appropriate changes. Step 5 discusses configuration mode.</p>
4	<p>CABLING</p> <p>Correct cables for the serial and parallel ports are vital for error free operation.</p>

Step	Instructions
	<p>A. Serial Ports</p> <p>Serial ports on Print Master are DCE. Therefore, straight cabling is required between the computer's serial port and Print Master's serial port. A straight cable is also required between Print Master's serial port and the serial port of a printer or plotter.</p> <p>B. Parallel Ports</p> <p>A straight through 25 pin parallel DB-25 male to DB-25 male cable is required to connect the parallel port of a computer to a parallel port of Print Master. A standard DB-25 male to centronics printer cable is required to connect the printer or plotter's parallel port to the parallel port of Print Master.</p> <p>Please see <i>Appendix A</i> of this manual for more cabling information.</p>
5	<p>CONFIGURATION MODE</p> <p>If you need to access configuration mode to change the port assignment or serial port configuration (see Steps 2 and 3 respectively), please see <i>Section 7</i> of this manual for instructions. If not, there is no need to access configuration mode.</p> <p>NOTE: The easiest way to access configuration mode is to use the supplied utility created by running the INSTALL program as described in <i>Section 4.2</i>. This utility is TERM.EXE for all models other than the 706A and 708A. The utility for the 706A and 708A models is PARSEND.EXE.</p>
6	<p>PORT SELECTION</p> <p>NOTE: If you will have only one printer or plotter connected, you may skip this step.</p> <p>You must select a printer port in multiple printer applications. The recommended methods to send the Port Select Code are:</p> <p>A. TSR - Select a port from a menu in the memory resident program using hot keys. See</p> <p>the README file generated by running the INSTALL program on the BayTech software utility diskette. When you run INSTALL, a menu titled "Printer Selection Programs" will appear on your screen. You are given three selections: RAMEXEC, RAMTSR, and WNDEXEC. Choose RAMEXEC if your PC runs non-Windows programs that do not operate in graphics mode. Choose RAMTSR if your PC runs non-Windows programs that operate in graphics mode. Choose WNDEXEC if your PC runs under Windows.</p> <p>B. Physically insert the Port Select Code as the first characters of the text or data in the</p> <p>document. See <i>Section 6.2.8</i> (Port Selection Methods) for more information concerning the Port Select Code.</p> <p>C. Create a separate file containing only the Port Select Code. See <i>Section 6.2.8</i> (Port Selection Methods) for more information.</p>
7	<p>MODE COMMANDS</p> <p>NOTE: If you are not connecting any serial PCs, you may skip this step.</p>

Step	Instructions
	<p>To print from a serial port of your PC, you must first redirect the parallel output to the serial port via the DOS command C:>MODE LPTx:=COMy:, where x and y are the port designation (e.g., LPT1:=COM1:). You must also configure your PC's serial port to communicate at parameters that match Print Master. This is done via the DOS command C:>MODE COMy: 9600,n,8,1,p, where y is the com port number of your PC. This MODE command assumes you are using factory default values. You may use the SMODE program to operate at serial speeds greater than 9600 bps.</p>
8	<p>AUTOEXEC.BAT FILE</p> <p>To use BayTech's RAMEXEC or RAMTSR software utilities to select between multiple peripherals, you must add commands to your PC's AUTOEXEC.BAT file. If you have to use any of the MODE commands mentioned in Step 7, you should add these commands to your AUTOEXEC.BAT file. See <i>Section 4.5 (PC Set-up)</i> for more information.</p>
9	<p>If you have any questions, please call BayTech technical support at 1-800-523-2702.</p>

4 INSTALLATION

4.1 UNPACKING

After opening the box, check the packing list that comes with Print Master to ensure that you have received all components. Also check the unit to make certain that it did not receive damage during shipping.

4.2 SOFTWARE UTILITY DISKETTE

BayTech provides utility software to assist you in configuring the Print Master. There are three peripheral selection programs included to provide easy device selection from text mode, graphics mode, or Windows.

IMPORTANT: Copy the BayTech original diskette onto a blank diskette and store the original in a safe place. Read your operating system's manual for copying instructions.

The software utility diskette provided with your Print Master comes with an automatic installation program called INSTALL. You must use this program to extract the compressed files associated with your unit. INSTALL automatically copies and expands the hidden files.

To run INSTALL, use the following procedure:

1. Insert the software utility diskette into drive A (or drive B) and from the prompt type **INSTALL** followed by <ENTER>.
2. A menu titled "Drive & Directory Definitions" will appear on your screen. This menu will display the *Source Drive*, *Destination Drive*, and *Destination Directory*. The Source Drive is the floppy drive where the diskette is inserted. The Destination Drive is the drive where the expanded files will be copied to (default is drive C). The Destination Directory is the directory where the files will be copied to (default is BAYTECH). If the default parameters do not match your application, you may use the <TAB> key or a mouse to change fields and type in the desired parameters. Once you have entered the appropriate values, select "OK".
3. A menu will appear on your screen titled "Series Definition". This menu will contain choices for the type of BayTech product you have purchased. Highlight "700 Series" with the arrow keys or mouse followed by "OK".
4. A menu titled "Printer Selection Programs" will appear on your screen. You are given three selections: RAMEXEC, RAMTSR, and WNDEXEC. Choose RAMEXEC if your PC runs non-Windows programs that do not operate in graphics mode. Choose RAMTSR if your PC runs non-Windows programs which operate in graphics mode. Choose WNDEXEC if your PC runs under WINDOWS. Select the desired program by highlighting it with the mouse or <TAB> key and depress the <SPACE BAR> followed by "OK".
5. When INSTALL is finished, you may review the instructions for the relevant files by referring to the README file copied to the Destination Directory. To view the README file on your screen, enter the command **TYPE README** from your subdirectory prompt. To print this file, enter the command **COPY README LPT1:** from your subdirectory prompt.

4.3 POWER

The Print Master requires 115 VAC, 50/60 Hz. power and comes with a three-prong power cord. Do not attempt to operate the unit with a two-prong socket or adapter. 230 VAC, 50/60 Hz. is optional.

The Print Master powers-up when you press the power switch on the back of the unit to "ON" or "1". Power-on is indicated on the front panel by the illuminating of a green LED.

CAUTION: Do not attempt to make any internal changes. Any upgrades to the EPROM or memory must be performed by an authorized service technician or by BayTech. Please contact BayTech at 1-800-523-2702 for more information.

4.4 FACTORY DEFAULTS

From the factory, Print Master is set up with Port 1 designated as a printer port. All other ports are factory-designated as computer ports. The highest numbered port is the master configuration port.

Other factory-default settings are: Input inactivity timeout is set to 20 seconds. The Port Select Code is \$PRINTER. The Port Select Mode is Mode 2 (selection anytime while sending). The Form Feed Mode and the Header Page Message are disabled. The Port Logical Name(s) are set as Device A, Device B, etc. Serial ports power-up from the factory at 9600 baud rate, 8 bit word size, 1 stop bit, no parity and XON/XOFF disabled.

If your application does not match this factory setup, you must first reconfigure Print Master by entering the configuration mode (see *Section 7*). If your application does match, you may proceed with the installation. For a description of the various changes that may be made by accessing the configuration mode, see *Section 6.1*.

4.5 PC SET-UP

This section provides instructions on how to set up your PC to work with Print Master with respect to the BayTech software (if you intend to use it) and special considerations when connecting your PC in serial.

If you intend to use the RAMEXEC or RAMTSR hot key programs to select between multiple peripherals, you would typically add the command **C:>RAMEXEC** or **C:>RAMTSR** to your PC's AUTOEXEC.BAT file. The subdirectory created by running the INSTALL program should be included in the PATH command. If using the WNDEXEC program for Microsoft Windows, you should follow the step by step instructions in the README file created by running the INSTALL program. Please see *Section 4.2* for INSTALL instructions.

NOTE: All users that wish to use the hot key software should have a copy of the program on their PC's hard drive. You may copy RAMEXEC (or RAMTSR) from a PC that has already configured this program using SETUP (or SETUPCFG) onto other PCs.

If connecting your PC to Print Master in serial, you would typically reroute the parallel output to the serial port via the DOS command **C:>MODE LPTx:=COMy:**, where x=1, 2, or 3 and y=1 or 2. This command should be included in your AUTOEXEC.BAT file. If you have a local parallel printer connected to your PC, you would not include this command in the AUTOEXEC.BAT file. Instead, you would have your applications software direct output to LPTx to print to the local printer or COMy to send print jobs to Print Master.

NOTE: If you have a local parallel printer connected to your PC and you wish to use RAMEXEC (or RAMTSR), set up the local printer to use LPT1 and RAMEXEC (or RAMTSR) to use LPT2. Then, you would add the command **MODE LPT2:=COMy:** to your AUTOEXEC.BAT file (where y = 1 or 2).

You will also need to change the serial port configuration of your PC's com port to match that of the Print Master. If using the Print Master's factory default serial configuration, this is accomplished via the DOS command **C:>MODE COMy: 9600, N, 8,1,P** where y is the number of the appropriate com port. This command should be part of your AUTOEXEC.BAT file. Alternatively, you may use the SMODE.EXE utility to operate at speeds greater than 9600 bps.

NOTE: All commands shown in bold print above and on the previous page should be located in your AUTOEXEC.BAT file after the PATH command and before any DOS shell commands. You should use DOS EDLIN or EDIT to modify your AUTOEXEC.BAT file. Please refer to your DOS documentation for instructions on EDLIN or EDIT. As an alternative, you may use the non-document mode of a word processing package such as Word Perfect to edit your AUTOEXEC.BAT file.

EXAMPLE: Suppose you are connecting your PC's COM1 port to Print Master using factory default serial parameters and you intend to use the RAMEXEC hot key software which has been copied to a subdirectory call BAYTECH. Your AUTOEXEC.BAT file would need to contain the following commands:

```
.  
.   
PATH=C:\...;C:\BAYTECH  
MODE LPT1:=COM1:  
MODE COM1: 9600,N,8,1,P  
RAMEXEC  
.   
.
```

The vertical dots before the PATH command and after the RAMEXEC command represent other commands that may be part of your AUTOEXEC.BAT file. The horizontal dots shown in the PATH command represent other subdirectories that may be part of the PATH command.

5 CABLING

Please see *Section 5.1* for parallel port cabling information, *Section 5.2* for DB-25 serial port cabling information, or *Section 5.3* for RJ-45 cabling. *Appendix A* provides recommended cabling pinouts.

5.1 PARALLEL PORTS

Parallel ports on Print Master have DB-25 female connectors. A straight, DB-25 male-to-male cable is required between each IBM PC computer (or compatible) and a parallel port on Print Master. A DB-25 male-to-Centronics cable is required between each printer having a Centronics connector and Print Master (i.e., IBM PC to Centronics cable).

CAUTION: Some standard EIA-232 DB-25 cables may have pin 1 grounded to connector shell. Since Pin 1 is a strobe line in Centronics protocol, this ground must be removed if the cable is used between a PC and Print Master.

The pin layout for the DB-25 connector is similar to IBM PC parallel connector and uses the following signals:

STANDARD TTL LEVELS

<u>SIGNAL NAME</u>	<u>DB-25 PIN NO.</u>
- Strobe	1
+ Data Bit 0	2
+ Data Bit 1	3
+ Data Bit 2	4
+ Data Bit 3	5
+ Data Bit 4	6
+ Data Bit 5	7
+ Data Bit 6	8
+ Data Bit 7	9
- Acknowledge	10
+ Busy	11
+ P. End (Out of Paper)	12
+ Select	13
- Auto Feed	14
- Error	15
- Initialize Printer	16
- Select Input	17
Ground	18-25

5.2 SERIAL PORTS

IMPORTANT: Before you proceed with cabling, you must know whether the devices that you will connect to Print Master are DTE (Data Terminal Equipment) or DCE (Data Communication Equipment). The following devices are generally DTE: terminals, printers, and computers like the IBM PC. The following devices are DCE: modems and some computers.

If your device transmits data on Pin 2 and receives data on Pin 3, it is DTE. If your device receives data on Pin 2 and transmits data on Pin 3, it is DCE. However, to verify the interface requirements, please refer to the Owner's Manual for your device.

Serial ports on Print Master have DB-25 female DCE connectors. DCE ports use the following signals for communication:

DCE PORT PIN/SIGNAL DEFINITION			
Pin	Signal (EIA-232)	Direction	Description
1	PGND	---	Protective Ground
2	Tx	Input	Data In
3	Rx	Output	Data Out
4	RTS	Input	Request To Send (Not Used)
5	CTS	Output	Clear To Send: - Voltage When Print Buffer Full
6	DSR	Output	Data Set Ready: + Voltage When Print Master Powers Up
7	SGND	---	Signal Ground
8	DCD	Output	Data Carrier Detect: + Voltage When Print Master Powers Up
20	DTR	Input	Print Master Transmit Enabled When +12 Volts. Internally Enabled If No Wire Connected.

DTE ports use the following signals for communication:

DTE PORT PIN/SIGNAL DEFINITION			
Pin	Signal (EIA-232)	Direction	Description
1	PGND	---	Protective Ground
2	Tx	Output	Data Out
3	Rx	Input	Data In
4	RTS	Output	Request To Send
5	CTS	Input	Clear To Send: Input handshake line. Must be positive voltage before DTE device will transmit data.
6	DSR	Input	Data Set Ready: Input handshake line. Must be positive voltage before DTE device will transmit data.
7	SGND	---	Signal Ground
8	DCD	Input	Data Carrier Detect: Generally used for modem communication.
20	DTR	Output	Data Terminal Ready: Output handshake line. DTE device will set this line to negative voltage when it can no longer receive data.

If you are interfacing a DTE device to Print Master (DCE), you must use a one-to-one or straight cable as in *Figure 2* on the following page. If you are interfacing a DCE device to Print Master, you must use a crossed cable as in *Figure 3* on the following page.

When using XON/XOFF protocol, it may be desirable to use cables with only Tx, Rx and SGND (signal ground) connected. On the serial ports of Print Master, input handshaking lines are enabled if nothing is connected allowing the system to operate with only Tx, Rx and SGND connected.

CAUTION: Do not attempt to use a serial cable on a parallel port. Since an EIA-232 serial port usually carries a potential of +12 and -12 volts, plugging a serial cable from that port into a parallel port may cause damage to the parallel port.

PRINT MASTER - DCE
MALE DB-25

DTE DEVICE
MALE/FEMALE DB-25

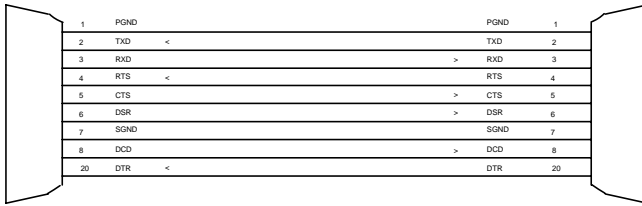

FIGURE 2

PRINT MASTER - DCE
MALE DB-25

DCE DEVICE
MALE DB-25

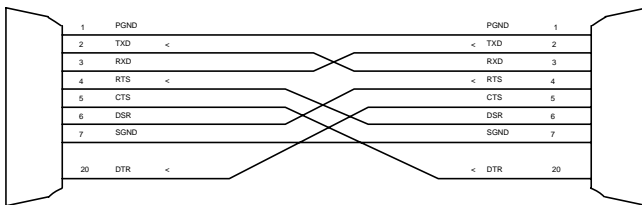

FIGURE 3

NOTE: Please refer to *Appendix A* for recommended cabling between Print Master and various computers and peripheral devices.

5.3 PRINT MASTER MODELS 706C, 708C AND 710C WITH RJ-45 MODULAR CONNECTORS

The EIA-232 serial ports of the Print Master Models 706C, 708C, or 710C may have RJ-45 modular connectors. This section will address the cabling and modular adapter information required for 700C models with RJ-45 modular connectors. BayTech has a complete line of RJ-45 adapters and cables that will make your installation quick and trouble free. Call your dealer or BayTech for order information.

The 700C models with modular connectors uses the following signals for communications:

RJ-45 PIN-OUT INFORMATION			
PIN	SIGNAL	DIRECTION	DESCRIPTION
1	RTS	Output	Handshake out, Normally +10V
2	DTR	Output	Handshake out, enable/disable the inputting of characters
3	TX	Output	Transmit Data
4	GND	----	Signal Ground
5	GND	----	Signal Ground
6	RX	Input	Receive Data
7	CTS	Input	Handshake In, enable/disable the outputting of characters
8	DSR	Input	Handshake In, not used.

Following are drawings of a RJ-45 receptacle and plug. The pin number assignments are given.

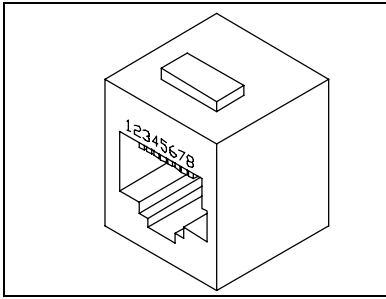

Figure 4: RJ-45 Receptacle

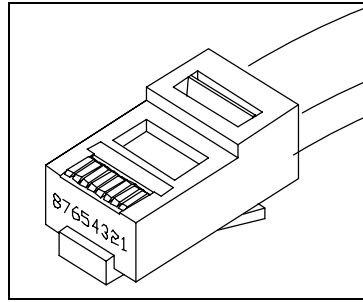

Figure 5: RJ-45 Plug

Please see *Appendix A.5* for modular adapter pinout and cabling information.

6 OPERATION

This section discusses the various user-programmable configurations (*Section 6.1*), printer sharing operation (*Section 6.2*), the LED indicators (*Section 6.3*), and data flow control (*Section 6.4*).

6.1 USER-PROGRAMMABLE CONFIGURATIONS

User-programmable configurations include the Port Logical Name, the Number of Printers/Port Assignment, the Printer Select Code, the Printer Select Mode, the Serial Port Configuration, the Input Inactivity Timeout, the Form Feed Mode, and the Header Page Message. The following subsections describe these parameters in detail.

6.1.1 THE PORT LOGICAL NAME

The Port Logical Name is simply an aid to identifying which device is connected to which port. It is used in the configuration menus and the Header Page Message. It has no function other than identification.

Factory default is Device A for Port 1, Device B for Port 2, ..., and Device J for Port 10.

6.1.2 THE NUMBER OF PRINTERS/THE PORT ASSIGNMENT

Individual ports on Print Master may be configured as computer or printer via the Number of Printers/Port Assignment. Computers connect to computer ports. Printers and plotters connect to printer ports.

On all models, a minimum of one port must be assigned as a printer port and a minimum of one port must be assigned as a computer port.

It is suggested that the highest numbered port, the master configuration port, be assigned as a computer port to allow easy access to all features of the configuration mode. The remaining ports may be user-designated as computer ports or printer ports in any combination except for the 700A and 700C models. Print Master automatically converts data from serial-to-parallel and parallel-to-serial.

On the 700A and 700C models, ports are assigned by defining the Number of Printers. Printer ports are assigned to the lowest numbered ports. For example, if the Number of Printers is 1, Port 1 is the printer port and the remaining ports are computer ports. If the Number of Printers is 3, Ports 1, 2, and 3 are printer ports and the remaining ports are computer ports.

On 700D, 700E and 700F models with combination serial/parallel ports, ports are defined by configuring the Port Assignment for individual ports to computer or printer. Any serial or parallel port may be assigned as a computer port or printer port.

NOTE: On Print Master models 710C, 710E and 710F, Port 10 may not be assigned as a printer port.

The factory default printer port on all Print Master models is Port 1 and all other ports are assigned as computer ports.

6.1.3 THE PRINTER SELECT CODE

To select a printer in multiple printer applications, the computer sends the Printer Select Code (which consists of any ASCII character string numbering from one to eight characters) followed by the desired printer port number.

The Printer Select Code is trapped by Print Master if it is valid and not passed to the printer. This code may be sent by inserting it into a file or by using BayTech's memory resident port select program which will automatically send it by striking hot keys or using a mouse.

Section 6.2 discusses how to use the Printer Select Code to select printer ports.

Factory default is \$PRINTER.

6.1.4 THE PRINTER SELECT MODE

In multiple printer applications, you can choose between two methods of selecting printers. Mode 1 allows the computer to select the printer at the beginning of printing only. The unit is transparent after 16 characters or more. Mode 2 is a general-purpose mode which allows the computer to select a printer anytime while printing by sending the new Printer Select Code.

NOTE: In Printer Select Mode 1 (beginning of printing only) the Model 706A and 708A will recognize the printer select code only if the very first characters of the print job contain the printer select code.

Factory default is Mode 2: selection anytime while sending.

6.1.5 THE SERIAL PORT CONFIGURATION

NOTE: This section is not applicable to the 706A or 708A models.

Print Master will translate for serial devices using different configurations. You may set the baud rate, word size, stop bits, parity and XON/XOFF for each individual serial port. The available values for these parameters are listed in *Section 2* (Specifications).

Factory default configuration on all serial ports is 9600 baud rate, 8 word size, 1 stop bit, no parity and XON/XOFF disabled.

6.1.6 THE INPUT INACTIVITY TIMEOUT

The input inactivity timeout allows Print Master to disconnect a computer from the unit if no characters are received from the computer for the specified timeout period.

Some application packages may have rather lengthy processing delay times between successive parts of the same file when printing. These delay times may exceed the factory default input inactivity timeout value of 20 seconds. Therefore, it may be necessary to increase the timeout to a higher value. Typical applications which may require a higher timeout would be ones which involve desk-top publishing, heavy graphics, and large text files with imbedded soft fonts.

Factory default is 20 seconds.

6.1.7 THE FORM FEED MODE

Print Master has four form feed modes which allow you to send a form feed to the selected printer. A form feed may be sent at the beginning of printing, at the end of printing, at the beginning and end of printing, or disabled (no form feed).

Factory default is no form feed.

6.1.8 THE HEADER PAGE MESSAGE

You may configure Print Master to print a programmable message and the logical name of the source computer on a separate sheet of paper before printing any other data. You may enable or disable the Header Page Message for each individual computer port.

Factory default is: This print job is for:, with the Header Page Message disabled.

6.2 PRINTER SHARING OPERATING PROCEDURE

Print Master allows printer (or plotter) sharing between multiple computers and a single printer or multiple printers. In multiple printer applications, users may contend for the next available printer on a first-in-first-out basis or select a specific printer. Print data is stored in the unit's buffer and sent to the printer as it can receive the information.

From the factory, Print Master is preset to allow multiple computers to share one printer. The default printer port is Port 1. If your application requires sharing multiple printers or if you will be sharing a single printer with an interface (parallel or serial) that does not match Port 1, you must access configuration mode and change the Port Assignment (or Number of Printers) for the appropriate port(s).

Please see the table below for a quick reference to the printer sharing operating procedure.

PRINTER SHARING QUICK REFERENCE	
Item	See Section
Sharing a single printer	6.2.1
Specified sharing of multiple printers	6.2.2
Contending for multiple printers	6.2.3
Buffering of print data	6.2.4
Beginning and ending a print job	6.2.5
Buffer clearing	6.2.6
Minimum size print job	6.2.7
Port selection methods	6.2.8
Full duplex communication	6.2.9
Plotter sharing hints	6.2.10

6.2.1 SHARING A SINGLE PRINTER

In applications where several users are sharing a single printer, printer sharing is automatic. You perform your normal print operation. There are no codes to send. Data is automatically sent to the printer. Print Master can receive print jobs simultaneously from all computers and will send the data to the printer in the same order it was received in the buffer.

6.2.2 SPECIFIED SHARING OF MULTIPLE PRINTERS

To select a specific printer in multiple printer applications, you must send a specific *printer select sequence* which consists of the Printer Select Code (factory set is *\$PRINTER*) followed by the desired printer port number. The Printer Select Code and port number are trapped if valid and not passed to the printer.

The printer port number then becomes the *printer assignment number* for your computer port. All subsequent print jobs sent without a printer select sequence will be sent to this printer port by default. If you desire to send print jobs to the same printer, there is no need to resend the Printer Select Code and the printer port number.

A print job may be sent to a printer port other than the default printer port without changing the default by sending a *temporary printer select sequence*. The temporary printer select sequence consists of the Printer Select Code followed by capital **T** and the desired printer port number. The next print job will go the temporary printer port. Subsequent print jobs sent without a Printer Select Code will be sent to the default printer port.

NOTE: If Print Master is reconfigured to add or delete a printer port (i.e., if you change the Port Assignment or Number of Printers), all default printer port assignments for the computer ports are erased and replaced with "0" for contention mode (see *Section 6.2.3*).

There are two modes for sending the Printer Select Code. In Printer Select Mode 2 (printer selection anytime while printing), Print Master looks for the Printer Select Code any time. If no Printer Select Code is received, the data will be routed to the default printer.

In Printer Select Mode 1 (printer selection at beginning of printing), Print Master looks for the start of the Printer Select Code in the first 16 characters received. If the first characters of the Printer Select Code are not received within 16 characters, the data will be routed to the previously designated printer. If the first characters of the Printer Select Code are received within 16 characters and a valid printer select sequence is then received, the new printer port number is stored and data will be routed to that printer.

NOTE: In Print Select Mode 1, the Model 706A and 708A will recognize the printer select code only if the very first characters of the print job contain the printer select code.

The printer select sequence may be sent manually from a computer keyboard, by inserting it into a file, or by using BayTech's support software. Please see *Section 6.2.8* for a description of various methods used to select specific printer ports.

6.2.3 CONTENDING FOR MULTIPLE PRINTERS

In multiple printer applications, if no specific printer is desired (i.e. if the print job may be sent to any printer), you may send the *printer contention sequence* which consists of the Printer Select Code (factory set is \$PRINTER) followed by **0** (zero). Print data received by Print Master's buffer is passed to the next available printer on a first-come-first-served basis. Print Master powers up from the factory in contention mode.

The printer contention sequence is trapped if valid and not passed to the printer. The printer contention sequence needs to be sent only once. It is then stored in non-volatile memory and will be effective on subsequent print jobs, until you send another printer select sequence.

6.2.4 BUFFERING OF PRINT DATA

When a user sends a print job, the data is stored in Print Master's spooling buffer (1 MB standard, available with 2 MB on 700C, 700D and 700E models; available with up to 4 MB on 700A models). All users may simultaneously send data to this dynamically allocated buffer. Therefore, the entire buffer could be occupied by data from one user if only one user is active or the buffer could be simultaneously distributed to all users.

Output is buffered and put into a queue in the same order in which it was sent to Print Master. The output is then sent to the printers in the same order in which it was queued.

6.2.5 BEGINNING AND ENDING A PRINT JOB

A print job starts when Print Master receives three or more characters from a computer. The characters must be sent in a time period shorter than the designated timeout.

In **Printer Select Mode 2**, a print job is ended when one of the following occurs:

1. No characters are received by Print Master from the computer for the specified input inactivity timeout period.
2. The computer sends the Printer Select Code.
3. The computer sends the clear buffer command (see *Section 6.2.6*).

4. The computer sends the Printer Select Code followed by a printer port number. If the port number is the same number as that of the current print job, this will indicate the end of the current print job, and the next print job will be routed to the same printer. If the port number is a different number from that of the current print job, this will indicate the end of the current print job, and the next print job will be routed to the newly selected printer.

NOTE: In **Printer Select Mode 2**, when the input inactivity timeout is set to 0 seconds, a print job is ended only when the computer sends the Printer Select Code followed by a printer port number or the clear buffer command.

In **Printer Select Mode 1**, a print job is ended when no characters are received by Print Master from the computer for the specified input inactivity timeout period.

CAUTION: The input inactivity timeout should not be set to 0 (zero) seconds in Printer Select Mode 1.

If Print Master's buffer fills, Print Master will drop the CTS line or send an XOFF to the computer, causing the computer to stop sending characters until the buffer can accept more data. In this case, the time that the computer is not sending characters is not counted as part of the input inactivity timeout.

6.2.6 BUFFER CLEARING

If you wish to clear a print job is sent in error, you must send the *clear buffer sequence* which consists of the Printer Select Code followed by **CLR**. This command will only affect print jobs originated by your computer. Print jobs in the buffer from other computers are not affected. The clear buffer sequence will clear the most recent print job sent to Print Master from your computer. This command will not clear a printer's buffer of data already passed to the printer from Print Master.

The clear buffer sequence is operable in either Printer Select Mode 1 or Mode 2. In Printer Select Mode 1, however, since Print Master is transparent after the first 16 characters are received, the computer must wait for the input inactivity timeout to occur before sending the clear buffer command. The clear buffer sequence may be sent by creating a clear buffer file or program (see *Section 6.2.8*).

NOTE: In Print Select Mode 1, the Model 706A and 708A will recognize the printer select code only if the very first characters of the print job contain the printer select code.

6.2.7 MINIMUM SIZE PRINT JOB

Print Master scans for a minimum size print job of three (3) characters. If more than 3 characters are received within the designated input inactivity timeout interval, the unit will treat these characters as a print job. If less than 3 characters are received, these characters will be discarded.

6.2.8 PORT SELECTION METHODS

BayTech provides utility software which allows you to conveniently select between peripherals for IBM DOS and Microsoft Windows applications. Port selection is as easy as activating hot keys or by using a mouse. Please see *Section 4.2* for more information.

There are alternative methods to peripheral selection. One method is to make the port select sequence the first characters of the text. These characters will be trapped by Print Master and not sent to the printer. This method will work only if the text of the print file is sent in an ASCII format.

You may wish to write your own program for sending the port select sequence to Print Master instead of inserting it into the document or utilizing the supplied support software. A simple procedure when using word processing programs is to create an ASCII file for each printer which contains the Port Select Code and printer port number. When you wish to select a particular device, you simply print this file followed by the actual print file.

You may use a DOS batch file to send a port select sequence. The DOS command typically used is the ECHO command. An example of the ECHO command used to select a printer connected to Port 2 using the default Port Select Code is the following:

ECHO \$PRINTER2>LPT1:.

This command should be entered in all capitals with only one space between ECHO and the \$. Please refer to your DOS manual for instructions on creating DOS batch files.

Programs such as Word Perfect and WordStar typically send a printer initialization string before any data. You may imbed the port select sequence in this string to select a printer. For example, Word Perfect allows you to edit the printer definition file for a specific printer by using the PTR command. The port select sequence for the Print Master would typically be inserted prior to any escape codes for the printer. Please see the documentation for your application package(s) for more information on editing printer initialization strings.

6.2.9 FULL DUPLEX COMMUNICATION

All serial ports on Print Master (except Models 706A and 708A) feature full duplex communication. The timeout interval is based on computer port input inactivity only. Full duplex allows the printer device to transmit a limited amount of data to the connected computer during the input inactivity timeout period. Communication back to the computer uses a 256-byte buffer with no handshaking.

6.2.10 PLOTTER SHARING HINTS

When using Print Master in a plotter sharing application, it is recommended that you send plot files to the Print Master rather than plotting dynamically from within your plotting software. You would typically have the application software direct the plot to a file and then copy the file to Print Master. This method eliminates the requirement for full duplex communication between the computer and the plotter which allows multiple computers to copy plot files simultaneously.

The DOS command to copy the plot file to Print Master typically adheres to the following format: **COPY <filename> /B COMy:**, where y is the number of the appropriate com port and <filename> is the name of the plot file.

It is still possible to plot dynamically through Print Master if required. When plotting in this fashion, you would probably need to increase the input inactivity timeout value to a higher number than factory default (20 seconds). Plotting dynamically would not allow you to utilize the buffering capabilities of Print Master because the data stream from the computer is not continuous. The dynamic method of plotting would allow only one user at a time access to the plotter due to the fact that the plotter can only respond back to the user who is currently connected through Print Master.

6.3 LED INDICATORS

All Print Master models have a green power LED and either six, eight, or ten red activity LEDs. The green power LED will illuminate whenever power is applied to the unit. The red LEDs indicate activity on the respective port(s) when illuminated while the unit is in operation mode. All red LEDs will illuminate briefly when the unit first powers up and goes through its self-test.

When a computer sends a print job to Print Master, the LED for the computer port and the selected printer port will illuminate. The computer LED will remain illuminated until a disconnection occurs as described in *Section 6.2.5*. The printer LED will typically remain illuminated until the connection with the sending computer is terminated. However, the printer LED may remain illuminated in the event multiple computers are sending print jobs to that printer simultaneously or if the printer attached to it goes off line (e.g., runs out of paper).

Whenever configuration mode for the model 706A or 708A is accessed (see *Section 7.1*), all red activity LEDs will illuminate.

6.4 DATA FLOW CONTROL

6.4.1 HARDWARE HANDSHAKING

COMPUTER-TO-PRINT MASTER-TO-PRINTER COMMUNICATION

When a computer transmits data to a printer through a Print Master computer port, the data is received and stored in the buffer which in turn retransmits it to the printer through a printer port. During transmission, after the buffer fills to where there is only 4K of memory remaining, Print Master will make the computer port's CTS (Clear-to-Send) line low (negative voltage), signaling the computer that it cannot accept any more data. However, Print Master can accept another 4K before overflowing the buffer.

When the buffer empties to where more than 4K remains (Print Master's buffer outputs 4K blocks of data), Print Master will make the CTS (Clear-To-Send) line high (positive voltage), signaling the computer that it can accept more data.

When Print Master retransmits the data to the printer and the printer cannot receive any more data, the unit will expect to see a low on the DTR (Data Terminal Ready) line. When the printer can receive more data, Print Master will expect to see a high on the DTR line.

PRINT MASTER-TO-COMPUTER COMMUNICATION

NOTE: Print Master will provide full duplex communication between a computer and printer which are connected through the unit. This section is applicable only when a device that is connected to a printer port is sending data back to a device connected to a computer port.

When Print Master is sending data to a computer through a computer port and the computer cannot receive any more data, Print Master will expect to see a low on the DTR line. When the computer can receive more data, Print Master will expect to see a high on the DTR line.

If Print Master sees a low on DTR from a computer, the unit will buffer data received by the printer device up to 256 characters. If the buffer fills, Print Master will not handshake with the printer sending data to the computer.

6.4.2 XON/XOFF HANDSHAKING

COMPUTER-TO-PRINT MASTER-TO-PRINTER COMMUNICATION

When a computer transmits data to a printer through a Print Master computer port, the data is received and stored in the buffer which in turn retransmits it to the printer through a printer port. During transmission, after the buffer fills to where there is only 4K of memory remaining, Print Master will make the computer port's CTS (Clear-to-Send) line low (negative voltage) or send an XOFF, signaling the computer that it cannot accept any more data. (However, in reality it can accept another 4K before overflowing the buffer.)

When the buffer empties to where more than 4K remains (Print Master's buffer outputs 4K blocks of data), Print Master will make the CTS (Clear-To-Send) line high (positive voltage) or send an XON, signaling the computer that it can accept more data.

When Print Master retransmits the data to the printer and the printer cannot receive any more data, the unit will expect to see a low on the DTR (Data Terminal Ready) line or receive an XOFF. When the printer can receive more data, Print Master will expect to see a high on the DTR line or receive an XON.

PRINT MASTER-TO-COMPUTER COMMUNICATION

NOTE: Print Master will provide full duplex communication between a computer and printer which are connected through the unit. This section is applicable only when a device that is connected to a printer port is sending data back to a device connected to a computer port.

When Print Master is sending data to a computer through a computer port and the computer cannot receive any more data, Print Master will expect to see a low on the DTR line or receive an XOFF. When the computer can receive more data, Print Master will expect to see a high on the DTR line or receive an XON.

If Print Master receives an XOFF character from a computer, the unit will buffer data received from the printer device up to 256 characters. If the buffer fills, Print Master *will not* handshake with the printer sending data to the computer.

6.4.3 HP 3000 OPTION

Print Master has a special option to order for the HP 3000 mini computer. When the HP 3000 sends an HP Laserjet inquiry command, Print Master will respond with an ASCII 0 (30 hex).

Please contact BayTech for purchasing information (see *Section 10*).

7 CONFIGURATION

Configuration changes are made through the master configuration port which is the highest numbered port on all models. Print Master will transmit configuration menus to the serial device connected to the master configuration port on all models except the 706A and 708A. The 706A and 708A will print out configuration menus on a parallel printer connected to Port 1 as described in *Section 7.1*. If you are configuring a 700C unit, please see *Section 7.2*. If you are configuring a 700D, 700E, or 700F unit, please see *Section 7.3*.

7.1 MODELS 706A AND 708A - CONFIGURATION PROCEDURE

Please use the following procedure to access configuration mode of the 706A or 708A and to program all the various features:

1. Connect a computer with a parallel port such as an IBM PC or compatible to Port 6 of the 706A or Port 8 of the 708A. Connect a printer with a parallel port to Port 1 of either unit. Please see *Section 5.1* and *Appendix A.4* for parallel cabling information.

Since configuration must be performed through a parallel port and since parallel communication is unidirectional, configuration menus must be printed out on your printer.

2. The computer must be in a mode that allows characters to be sent from the keyboard to the parallel port. To put your computer into this mode, Bay Tech provides a utility program (**PARSEND**) or a suggested program to run using MS BASIC (see *Section 4.2*).

NOTE: Make sure the keyboard of your computer is in the CAPS LOCK position.

All ports on the Print Master 706A or 708A must be inactive (i.e., only the green power LED should be illuminated).

With the PARSEND or MS BASIC program loaded on your PC, send from the keyboard ***Control-T*** followed by capital **C**. These characters will not print on the printer. The Model 706A or 708A will respond with the main configuration menu which should print out on your printer. When configuration mode is been accessed, all the red LEDs on the front panel will illuminate.

NOTE: If only two red LEDs illuminate when *Control-T* and capital C are sent or if the unit gives no response, this indicates that an incorrect character sequence has been received. If so, wait for the unit to time-out (LEDs will go out) and re-send *Control-T* and the ASCII capital C.

From this point on, configuration of the Model 706A or 708A will be menu driven.

For illustration purposes, we show the configuration menus for the 706A. The only notable exceptions between the 706A and 708A configuration menus are the actual number of ports shown in the menus.

7.1.1 MODELS 706A AND 708A - MAIN CONFIGURATION MENU

Print Master 706A and 708A will respond to the receiving of *Control-T* and *C* by sending to the printer on Port 1 the following identification block and a menu of the configuration options available:

```
Bay Technical Associates
  Model 706A Print Master
  Copyright 1989
  Revision 3.00
  Total Memory : 1024K Bytes

Status.....1
Change Logical Name.....2
Set Input Inactivity Timeout.....3
Set Number of Printers.....4
Program Printer Select Code.....5
Set Printer Select Mode.....6
Set Form Feed Mode.....7
Program Header Page Message.....8
Exit.....X

Enter Request:
```

NOTE: Menu selection is case sensitive. It is recommended that your keyboard be in the CAPS LOCK position.

7.1.2 MODELS 706A AND 708A - STATUS

By responding to the *Enter Request:* message at the end of the main configuration menu with "1" (Status), you may review the current configuration status of the 706A and 708A. Print Master will respond with:

Current Printer Port Configuration

Port	Logical Name	Prnt Assn
1	Device A	1

Current Computer Port Configuration

Port	Logical Name	Prnt Assn
2	Device B	0
3	Device C	0
4	Device D	0
5	Device E	0
6	Device F	0

Press any Key to continue

```
Input Inactivity Timeout is.....20 seconds
Number of Printers is.....1
Printer Select Code is.....$PRINTER
Printer Select Mode is.....2
Form Feed Mode is.....1
Header Page Message is (OFF):
    This print job is for :
```

```
Status.....1
Change Logical Name.....2
Set Input Inactivity Timeout.....3
Set Number of Printers.....4
Program Printer Select Code.....5
Set Printer Select Mode.....6
Set Form Feed Mode.....7
Program Header Page Message.....8
Exit.....X
```

Enter request:

You may now make whatever changes are necessary by responding to the above menu. The Exit selection (capital **X**) will return you to the Operations Mode.

7.1.3 MODELS 706A AND 708A - CHANGE LOGICAL NAME

By responding to the *Enter Request:* message at the end of the main configuration menu with "2" (Change Logical Name), you may change the identifying name for the device on each port. Print Master 706A and 708A will respond with:

Enter Port Number (1 to 6, 0=Exit), CR:

Type the number of the desired port followed by <ENTER>. For example, if you type "1" Master will respond with:

Port	Logical Name	Prnt Assn
1	Device A	1

Enter Logical name:

Enter the new logical name for Port 1. For example, if you enter *LaserJet*, Print Master will respond with:

Port	Logical Name	Prnt Assn
1	Device A	1

Enter Port Number (1 to 6, 0=Exit),CR:

If you wish to change the logical name of another port, enter that port number followed by <ENTER> and repeat the above procedure. If no additional changes are required, send 0 (zero) followed by <ENTER>.

Print Master will save all changes permanently in non-volatile memory and return to the main configuration menu (*see Section 7.1.1*).

7.1.4 MODELS 706A AND 708A - SET INPUT INACTIVITY TIMEOUT

By responding to the *Enter Request:* message at the end of the main configuration menu with "3" (Set Input Inactivity Timeout), you may set the input inactivity timeout. Print Master will automatically disconnect the computer if no characters are received from the computer for the specified timeout period.

Print Master 706A and 708A will respond with:

```
Input Inactivity Timeout is.....20 seconds
Enter Timeout (0 to 200), hit return.....:
```

Enter the number of timeout seconds that you wish from 0 to 200, followed by <ENTER>.

NOTE: If 0 (zero) is entered, the input inactivity timeout will be disabled, and the end of a print job will occur only when the computer sends the Printer Select Code followed by a printer port number.

CAUTION: Do not set the input inactivity timeout to zero seconds when Printer Select Mode 1 has been selected. Mode 1 recognizes the end of a print job by input inactivity timeout only. It does not recognize a manual disconnect.

Print Master will save the new input inactivity timeout permanently in non-volatile memory and return to the main configuration menu (see *Section 7.1.1*).

7.1.5 MODELS 706A AND 708A - SET NUMBER OF PRINTERS

By responding to the *Enter Request:* message at the end of the main configuration menu with "4" (Set Number of Printers), you may change the number of computer ports and printer ports.

Print Master 706A will respond with:

```
Number of printers is.....1
Enter Number of Printers (1 to 5).....:
```

Enter the number of printers that you desire.

NOTE: Print Master 708A will show the Number of Printer from 1 to 7.

IMPORTANT: The *lowest-numbered* ports on Print Master Models 706A and 708A are reserved as printer ports. The Model 706A has a total of six available ports; as many as five of these ports may be printer ports with the remainder reserved as computer ports. The Model 708A has a total of eight available ports; as many as seven of these ports may be printer ports with the remainder reserved as computer ports.

For example, if you configure two printer ports, these would be ports 1, 2. If you configure four printer ports, these would be ports 1, 2, 3, and 4. They may not be configured in any other order.

NOTE: When the number of printers is changed, the printer assignment number on all computer ports automatically resets to 0 putting the computers in the printer contention mode.

Print Master will save the new number of printers permanently in non-volatile memory and return to the main configuration menu (see *Section 7.1.1*).

7.1.6 MODELS 706A AND 708A - PROGRAM PRINTER SELECT CODE

By responding to the *Enter Request:* message at the end of the main configuration menu with "5" (Set Printer Select Code), you may change the Printer Select Code to a user-defined code. The Printer Select Code consists of any character string from 1 to 8 ASCII characters.

Print Master will respond with:

```
Printer Select Code is.....$PRINTER
Enter Printer Select Code
(0 to 8 Chrs, Hit Return).....:
```

Enter the new Printer Select Code, followed by <ENTER> or just <ENTER> for no change.

NOTE: Non-printable characters are acceptable, but they will not appear in the Status print-out. If you are using the BayTech utility software to select printers, be certain to change the Printer Select Code in the software as well.

Print Master will save the new Printer Select Code permanently in non-volatile memory and return to the main configuration menu (*see Section 7.1.1*).

7.1.7 MODELS 706A AND 708A - SET PRINTER SELECT MODE

By responding to the *Enter Request:* message at the end of the main configuration menu with "6" (Set Printer Select Mode), you may change the method of selecting printers.

Print Master 706A and 708A will respond with:

```
Select Printer -  
At the Beginning of Printing Only...1  
Anytime While Printing.....2  
  
Printer Select Mode is.....2  
Enter Printer Select Mode.....:
```

Enter the new Printer Select Mode. Print Master will save the new mode permanently in non-volatile memory and return to the main configuration menu (*see Section 7.1.1*).

7.1.8 MODELS 706A AND 708A - SET FORM FEED MODE

By responding to the *Enter Request:* message at the end of the main configuration menu with "7" (Set Form Feed Mode), you may select one of four form feed modes.

Print Master will respond with:

```
No Form Feed.....1  
Form Feed at the Beginning of Printing....2  
Form Feed at the End of Printing.....3  
Form Feed at the Beginning and End.....4  
  
Form Feed Mode is.....1  
Enter Form Feed Mode.....:
```

Enter the new Form Feed Mode that you want. Print Master will save the new form feed mode permanently in non-volatile memory and return to the main configuration menu (*see Section 7.1.1*).

7.1.9 MODELS 706A AND 708A - PROGRAM HEADER PAGE MESSAGE

By responding to the Enter request: message at the end of the main configuration menu with "8" (Program Header Page Message), you may enable or disable this message and program its content.

Print Master will respond with the following:

```
Header Page Message is (OFF):  
This print job is for:
```

```
Enter Header Page Message  
(0 to 80 chrs, Ctrl C = Terminate):
```

Enter the new message, followed by *Control-C*. Note that the message will print on paper exactly as it is placed on the CRT screen. The message may appear on one line or several lines. If several lines are desired, each line must be ended by *Carriage Return* and *Line Feed (Control-J)*.

If no change in the message is desired, send *Control-C* only, and the current message will be retained. Print Master will then respond with:

```
Print Header Page (R/Y/N)?.....:
```

If you enter *R* (repeat), the entire sequence will be repeated, and you may re-enter the Header Page Message. If you enter *Y* (yes), the new Header Page Message will be stored permanently in non-volatile memory and will print on all subsequent print jobs. If you enter *N* (no), the Header Page Message will be disabled and will not print. The new message, however, will be stored permanently in non-volatile memory. Print Master will now return to the main configuration menu (see Section 7.1.1).

7.1.10 MODELS 706A AND 708A - EXIT

To exit the configuration mode, send capital **X** in response to the prompt at the end of the main configuration menu, and Print Master will return to the operating mode.

7.2 ALL 700C MODELS - CONFIGURATION PROCEDURE

All configuration changes must be made through the master configuration port. This master configuration port has access to all options of the configuration mode. Please use the following procedure to configure your Print Master 700C model:

1. Connect a dumb terminal (or a PC running a terminal emulation program) to the master configuration port which is Port 6 on the 706C, Port 8 on the 708C, Port 10 on the 710C. From the factory, all serial ports are preset at 9600 baud rate, 8 word size, 1 stop bit, no parity and XON/XOFF disabled.

NOTE: If you wish to use the BayTech TERM.EXE program to configure your unit, refer to the instructions on the following page.

2. Make sure the keyboard of your computer is in the CAPS LOCK position.

All ports on Print Master must be off-line (i.e, all LEDs must be off except for the green power LED).

Send from the keyboard of the terminal or the PC ***Control-T*** (14 Hex) followed by capital **C** (43 Hex). These characters will not appear on the CRT screen.

If any red LEDs on Print Master illuminate when *Control-T* and C are sent or if Print Master gives no response (no menus appear), this indicates that an incorrect character sequence has been received. If so, wait for Print Master to time out (LEDs will go out) and resend *Control-T* and capital C.

The Model 700C will respond with the main configuration menu. From this point on, configuration of the 700C models will be menu driven.

If you do not have a dumb terminal or a terminal emulation program, BayTech supplies a utility diskette which includes software to put an IBM PC or compatible into a terminal mode. See *Section 4.2* for instructions to obtain the software (TERM.EXE) by running the INSTALL.EXE program if you have not already done so.

Once you have obtained TERM.EXE, use the following procedure:

1. From the BAYTECH subdirectory prompt enter: **term.**

The program will respond with an identification block and configuration menu for the PC COM port similar to the following:

PC's Configuration					Handshaking				
Port	Baud Rate	Word Size	Stop Bits	Parity	RTS	CTS	DSR	DCD	DTR
Com1	9600	8	1	N	Hi	Hi	Hi	n/a	Hi

You are now in the terminal emulation mode with full duplex communication. Any characters you type from the keyboard will be transmitted out of the PC COM port to Print Master. They will not appear on the CRT screen. Any characters received from Print Master by the PC COM port will be displayed on the CRT screen.

2. Ensure the displayed PC Configuration is correct. If not, enter ALT-C to change. For example, if you have your serial cable physically connected to COM2 on your PC, first type ALT-C followed by the up arrow key and then <ENTER> to have the TERM program switch to COM2.

3. Refer to the upper right hand corner of the screen for Handshaking line status. RTS, CTS, DSR, and DTR should all be HIGH. The DCD line is not looked at by the terminal emulation program therefore its status can be ignored. If these signals are not high at this point, check to ensure the correct cable is connected.
4. Depress function key: **F1**.

NOTE: The **F1** key in TERM sends the character sequence **Control-T** (14 Hex) followed by the capital **C** character (43 Hex).

The main configuration menu will appear as shown in *Section 7.2.1*. From this point on, configuration of Print Master will be accomplished by following the menus that will prompt you.

7.2.1 ALL 700C MODELS - MAIN CONFIGURATION MENU

Print Master will respond to the receiving of *Control-T* and capital *C* with an identification block and a menu of the configuration options available, similar to the following for the Model 706C:

```

Bay Technical Associates
Model 706C Print Master
Copyright 1989
Revision 3.00
Total Memory : 1024K Bytes

Status.....1
Set Serial Port Configuration.....2
Set Input Inactivity Timeout.....3
Set Number of Printers.....4
Program Printer Select Code.....5
Set Printer Select Mode.....6
Set Form Feed Mode.....7
Program Header Page Message.....8
Exit.....X

```

Enter Request:

NOTE: Menu selection is case sensitive. It is recommended that your keyboard be in the CAPS LOCK position.

7.2.2 ALL 700C MODELS - STATUS

By responding to the *Enter Request:* message at the end of the main configuration menu with "1" (Status), you may review the status of the current configuration of Print Master.

Print Master will respond with a menu similar to:

Current Printer Port Configuration

Port	Baud Rate	Word Size	Stop Bits	Parity	Logical Name	Xon/Xoff	Prnt Assn
1	9600	8	1	None	Device B	Off	0

(Press any key to continue)

Current Computer Port Configuration

Port	Baud Rate	Word Size	Stop Bits	Parity	Logical Name	Xon/Xoff	Prnt Assn
2	9600	8	1	None	Device B	Off	0
3	9600	8	1	None	Device C	Off	0
4	9600	8	1	None	Device D	Off	0
5	9600	8	1	None	Device E	Off	0
6	9600	8	1	None	Device F	Off	0

Input inactivity timeout is.....20 seconds

Number of printers is.....1

Printer Select Code is.....\$PRINTER

Printer Select Mode is.....2

Form Feed Mode is.....1

Header Page Message is (OFF):

This print job is for :

(Press any key to continue)

Status.....1

Set Serial Port Configuration.....2

Set Input Inactivity Timeout.....3

Set Number of Printers.....4

Program Printer Select Code.....5

Set Printer Select Mode.....6

Set Form Feed Mode.....7

Program Header Page Message.....8

Exit.....X

Enter Request:

You may now make whatever changes are necessary by responding to the above menu. The *Exit* selection (capital X) will return you to the Operations Mode.

7.2.3 ALL 700C MODELS - SET SERIAL PORT CONFIGURATION

By responding to the *Enter Request:* message at the end of the main configuration menu with "2" (Set Serial Port Configuration), you may change the serial configuration of each port (i.e. baud rate, word size, stop bits, parity, and XON/XOFF). Each port may be configured individually. This allows Print Master to translate for devices using different configurations.

You may also assign or change the Logical Name for each port. Logical names are simply an aid to identifying port assignment; they have no other function.

Print Master will respond with:

Enter Port Number (1 to 6), hit return:

Type the desired port number followed by <ENTER>. For example, if you type "5" and <ENTER>, Print Master will respond with the current status of Port 5 and a menu of the available options:

Port	Baud Rate	Word Size	Stop Bits	Parity	Logical Name	Xon/Xoff	Prnt Assn
5	9600	8	1	None	Device E	OFF	0

Exit/save.....1 Set stop bits.....4 Set logical name...7
Set baud rate..2 Set parity.....5
Set word size..3 Set Xon/Xoff.....6

Enter request:

You may now reconfigure Port 5 by selecting the appropriate option from the menu. For example, to change the baud rate to 2400 baud, send character "2" (Set baud rate). Print Master will respond with this menu:

- 1 For 110
- 2 For 135
- 3 For 300
- 4 For 600
- 5 For 1200
- 6 For 2400
- 7 For 4800
- 8 For 9600
- 9 For 19200

Enter request:

Send "6" for 2400 baud rate, and Print Master will respond with the reconfigured status of the port:

Port	Baud Rate	Word Size	Stop Bits	Parity	Logical Name	Xon/Xoff	Prnt Assn
5	2400	8	1	None	Device E	Off	0

Exit/save.....1 Set stop bits.....4 Set logical name...7

Set baud rate..2 Set parity.....5

Set word size..3 Set Xon/Xoff.....6

Enter request:

If you wish to make other configuration changes for Port 5, you may do so by responding to the menu. If there are no other changes for this port, send "1" (Exit/Save), and Print Master will respond with:

Save Changes Permanently? (Y/N):

NOTE: When changing the configuration of the master configuration port, Print Master will also respond with:

Change Host Device to NEW Configuration
Before Answering This Request.

This reminds you to make sure the configuration of the terminal matches the new configuration of the master configuration port. If they do not match, you will be locked out of Print Master and unable to access its functions.

CAUTION: If Y is sent before changing the configuration device to the new configuration (baud rate or parity), Print Master will not receive the Y response. However, you will be locked out of Print Master. If this occurs, recycle Print Master power. Print Master's configuration will default back to the last saved configuration. You must then re-enter configuration and re-save the configuration of the configuration port.

If you answer Y (yes), the new configuration for that port will be stored permanently in non-volatile memory, and Print Master will subsequently power-up at that configuration.

If you answer N (no), the new configuration will be stored in RAM, and on the next power-up, Print Master will revert to the previous configuration.

NOTE: The Y and N responses must be upper case. If a lower case Y is entered, Print Master will interpret it as "no" and the changes you have made will not be saved permanently in memory.

IMPORTANT: Ports 9 and 10 on the model 710C must have matching baud rates, word size, stop bits and parity. When you configure either Port 9 or Port 10 individually, Print Master will automatically set the other port to match. This does not affect XON/XOFF or Logical Name settings, which are set individually.

Print Master will now return to the main configuration menu (see *Section 7.2.1*).

7.2.4 ALL 700C MODELS - SET INPUT INACTIVITY TIMEOUT

By responding to the *Enter Request:* message at the end of the main configuration menu with "3" (Set Input Inactivity Timeout), you may set the input inactivity timeout. Print Master will automatically disconnect the computer if no characters are received for the specified timeout period.

Print Master will respond with:

```
Timeout is.....20 seconds  
Enter Timeout (0 to 200), hit return.....:
```

Type the number of timeout seconds that you wish from 0 to 200, followed by <ENTER>.

WARNING: If you type <ENTER> without entering a value in response to the prompt, the input inactivity timeout will automatically set to 0 (zero) seconds, disabling the timeout.

CAUTION: Do not set the input inactivity timeout to zero seconds when Printer Select Mode 1 has been selected. Mode 1 recognizes the end of a print job by input inactivity timeout only. It does not recognize a manual disconnect.

Print Master will save the new input inactivity timeout permanently in non-volatile memory and return to the main configuration menu (see *Section 7.2.1*).

7.2.5 ALL 700C MODELS - SET NUMBER OF PRINTERS

By responding to the *Enter Request:* message at the end of the main configuration menu with "4" (Set Number of Printers), you may change the number of printers.

IMPORTANT: The lowest-numbered ports on the 706C, 708C and 710C Print Masters are reserved as printer ports. For example, the Model 706C has a total of six available ports of which as many as five may be printer ports with the remainder reserved as computer ports. If you configure two printer ports on Print Master 706C, these would be ports 1 and 2. If you configure four printer ports, these would be ports 1, 2, 3, and 4. Printer ports may not be configured in any other order.

Print Master will respond with:

```
Number of printers is.....1
Enter Number of Printers (1 to 5).....:
```

Enter the number of printers that you desire.

NOTE: When the number of printers is changed, the printer assignment number on all computer ports automatically resets to 0 (zero), putting the computers in the printer contention mode.

Print Master will save the new number of printers permanently in non-volatile memory and return to the main configuration menu (*see Section 7.2.1*).

7.2.6 ALL 700C MODELS - PROGRAM PRINTER SELECT CODE

By responding to the *Enter Request:* message at the end of the main configuration menu with "5" (Program Printer Select Code), you may change the Printer Select Code to a user-defined code. The Printer Select Code consists of any character string from 1 to 8 ASCII characters.

Print Master will respond with the following:

```
Printer Select Code is.....$PRINTER
Enter Printer Select Code
(0 to 8 Chrs, Hit Return=Terminate).....:
```

Type the new Printer Select Code followed by <ENTER> or just <ENTER> for no change.

NOTE: Non-printable characters are acceptable, but they will not appear in the status menu. If you are using the BayTech utility software to select printers, be certain to change the Printer Select Code in the software as well.

Print Master will save the new Printer Select Code permanently in non-volatile memory and return to the main configuration menu (see *Section 7.2.1*).

7.2.7 ALL 700C MODELS - SET PRINTER SELECT MODE

By responding to the *Enter Request:* message at the end of the main configuration menu with "6" (Set Printer Select Mode), you may change the method of selecting printers.

Print Master will respond with:

```
Select Printer -  
At the Beginning of Printing Only...1  
Anytime While Printing.....2  
  
Printer Select Mode is.....2  
Enter Printer Select Mode.....:
```

You should then enter the Printer Select Mode you want. Print Master will save the new mode permanently in non-volatile memory and return to the main configuration menu (*see Section 7.2.1*).

7.2.8 ALL 700C MODELS - SET FORM FEED MODE

By responding to the *Enter Request:* message at the end of the main configuration menu with "7" (Set Form Feed Mode), you may select one of four form feed modes.

Print Master will respond with:

```
No Form Feed.....1  
Form Feed at the Beginning of Printing....2  
Form Feed at the End of Printing.....3  
Form Feed at the Beginning and End.....4  
  
Form Feed Mode is.....1  
Enter Form Feed Mode.....:
```

You should then enter the Form Feed Mode you want. Print Master will save the new form feed mode permanently in non-volatile memory and return to the main configuration menu (*see Section 7.2.1*).

7.2.9 ALL 700C MODELS - PROGRAM HEADER PAGE MESSAGE

By responding to the Enter request: message at the end of the main configuration menu with "8" (Program Header Page Message), you may enable or disable this message and program its content. Print Master will respond with:

Header Page Message is (OFF):
This print job is for:

Enter Header Page Message
(0 to 80 chrs, Ctrl C = Terminate):

Enter the new message followed by *Control-C*. Note that the message will print on paper exactly as it is placed on the CRT screen. The message may appear on one line or several lines. If several lines are desired, each line must be ended by *Carriage Return* and *Line Feed (Control-J)*. If no change in the message is desired, send *Control-C* only, and the current message will be retained.

Print Master will respond with:

Print Header Page (R/Y/N)?.....:

If you enter *R* (repeat), the entire sequence will be repeated, and you may re-enter the Header Page Message. If you enter *Y* (yes), the new Header Page Message will be stored permanently in non-volatile memory and will print on all subsequent print jobs. If you enter *N* (no), the Header Page Message will be disabled and will not print. The new message, however, will be stored permanently in non-volatile memory. Print Master will now return to the main configuration menu (see *Section 7.2.1*).

7.2.10 ALL 700C MODELS - EXIT

To exit the configuration mode, send capital **X** in response to the prompt at the end of the main configuration menu, and Print Master will return to the operating mode.

7.3 ALL 700D, 700E, 700F MODELS - CONFIGURATION PROCEDURE

All configuration changes must be made through the master configuration port. This master configuration port has access to all options of configuration mode. Please use the following procedure to configure your Print Master 700D, 700E, or 700F model:

1. Connect a dumb terminal (or a PC running a terminal emulation program) to the master configuration port which is Port 6 on the 706D and 706E; Port 8 on the 708D, 708E and 708F; Port 10 on the 710E and 710F. From the factory, all serial ports are preset at 9600 baud rate, 8 word size, 1 stop bit, no parity and XON/XOFF disabled.

NOTE: If you wish to use the BayTech TERM.EXE program to configure your unit, refer to the instructions on the following page.

2. Make sure the keyboard of your computer is in the CAPS LOCK position.

All ports on Print Master must be off-line (i.e., all LEDs must be off except the green power LED).

Send from the keyboard of the terminal or the PC ***Control-T*** followed by capital **C**. These characters will not appear at on the CRT screen, but Print Master will respond with the main configuration menu.

If any red LEDs on Print Master illuminate when *Control-T* and C are sent or if Print Master gives no response (no menus appear), this indicates that an incorrect character sequence has been received. If this occurs, wait for Print Master to timeout (LEDs will go out) and resend *Control-T* and capital C.

If you do not have a dumb terminal or a terminal emulation program, BayTech supplies a utility diskette which includes software to put an IBM PC or compatible into a terminal mode. See *Section 4.2* for instructions to obtain the software (TERM.EXE) by running the INSTALL.EXE program if you have not already done so.

Once you have obtained TERM.EXE, use the following procedure:

1. From the BAYTECH subdirectory prompt enter: **term.**

The program will respond with an identification block and configuration menu for the PC COM port similar to the following:

PC's Configuration					Handshaking				
Port	Baud Rate	Word Size	Stop Bits	Parity	RTS	CTS	DSR	DCD	DTR
Com1	9600	8	1	N	Hi	Hi	Hi	n/a	Hi

You are now in the terminal emulation mode with full duplex communication. Any characters you type from the keyboard will be transmitted out of the PC COM port to Print Master. They will not appear on the CRT screen. Any characters received from Print Master by the PC COM port will be displayed on the CRT screen.

2. Ensure the displayed PC Configuration is correct. If not, enter ALT-C to change. For example, if you have your serial cable physically connected to COM2 on your PC, first type ALT-C followed by the up arrow key and then <ENTER> to have the TERM program switch to COM2.

3. Refer to the upper right hand corner of the screen for Handshaking line status. RTS, CTS, DSR, and DTR should all be HIGH. The DCD line is not looked at by the terminal emulation program therefore its status can be ignored. If these signals are not high at this point, check to ensure the correct cable is connected.
4. Depress function key: **F1**. The **F1** key in TERM sends the character sequence **Control-T** (14 Hex) followed by the capital **C** character (43 Hex).

Make sure the keyboard of your computer or terminal is in the CAPS LOCK position.

The main configuration menu will appear as shown in *Section 7.3.1*. From this point on, configuration of Print Master will be accomplished by following the menus that will prompt you.

7.3.1 ALL 700D, 700E, 700F MODELS - MAIN CONFIGURATION MENU

Print Master will respond to the receiving of *Control-T* and capital *C* with an identification block and a menu of the configuration options available, similar to the following:

```

Bay Technical Associates
Model 706D Print Master
Copyright 1989
Revision 3.00
Total Memory : 1024K Bytes

Status.....1
Set Serial Port Configuration.....2
Change Port Logical Name.....3
Set Port Assignment.....4
Set Input Inactivity Timeout.....5
Program Printer Select Code.....6
Set Printer Select Mode.....7
Set Form Feed Mode.....8
Program Header Page Message.....9
Exit.....X

```

Enter Request:

7.3.2 ALL 700D, 700E, 700F MODELS - STATUS

By responding to the *Enter Request:* message at the end of the main configuration menu with 1 (Status), you may review the status of the current configuration of Print Master. Print Master will respond with a menu similar to:

Port	Logical Name	Port Type	Port Assignt	Prnt Assn
1	Device A	Parall	Printer	1
2	Device B	Parall	Computer	0
3	Device C	Parall	Computer	0
4	Device D	Parall	Computer	0
5	Device E	Serial	Computer	0
6	Device F	Serial	Computer	0

Port	Baud Rate	Word Size	Stop Bits	Pariity	Xon/ Xoff
5	9600	8	1	None	Off
6	9600	8	1	None	Off

Press any Key to continue

Input inactivity timeout is.....20 seconds
 Number of printers is.....1
 Printer Select Code is.....\$PRINTER
 Printer Select Mode is.....2
 Form Feed Mode is.....1
 Header Page Message is (OFF):

This print job is for :

```
Status.....1
Set Serial Port Configuration.....2
Change Port Logical Name.....3
Set Port Assignment.....4
Set Input Inactivity Timeout.....5
Program Printer Select Code.....6
Set Printer Select Mode.....7
Set Form Feed Mode.....8
Program Header Page Message.....9
Exit.....X
```

Enter Request:

You may now make whatever changes are necessary by responding to the above menu. The Exit selection (capital **X**). will return you to the Operations Mode.

7.3.3 ALL 700D, 700E, 700F MODELS -SET SERIAL PORT CONFIGURATION

By responding to the *Enter Request:* message at the end of the main configuration menu with "2" (Set Serial Port Configuration), you may change the configuration of each serial port (i.e. baud rate, word size, stop bits, parity, and XON/XOFF). Each port may be configured individually. This allows Print Master to translate for devices using different configurations.

Print Master will respond with a menu similar to:

Enter Port Number (5 to 6, 0=Exit), CR:

Type the desired port number followed by <ENTER>. For instance, if you type "5" and <ENTER>, Print Master will respond with the current status of Port 5 and a menu of the available options:

Port	Baud Rate	Word Size	Stop Bits	Pariiity	Xon/Xoff
5	9600	8	1	None	Off

Exit/save.....1 Set stop bits.....4
Set baud rate..2 Set parity.....5
Set word size..3 Set Xon/Xoff.....6

Enter request:

You may now reconfigure Port 5 by selecting the appropriate option (1-6) from the menu. For example, to change the baud rate to 2400 baud, send character "2" (Set baud rate). Print Master will respond with this menu:

- 1 For 110
- 2 For 135
- 3 For 300
- 4 For 600
- 5 For 1200
- 6 For 2400
- 7 For 4800
- 8 For 9600
- 9 For 19200

Enter request:

Send "6" for 2400 baud rate, and Print Master will respond with the reconfigured status of the port:

Port	Baud Rate	Word Size	Stop Bits	Paritiy	Xon/Xoff
5	2400	8	1	None	Off

Exit/save.....1 Set stop bits.....4
Set baud rate..2 Set parity.....5
Set word size..3 Set Xon/Xoff.....6

Enter request:

If you wish to make other configuration changes for Port 5, you may do so by responding to the menu. If there are no other changes for this port, send "1" (Exit/Save), and Print Master will respond with:

Save Changes Permanently? (Y/N):

NOTE: When changing the configuration of the master configuration port, Print Master will also respond with:

Change Host Device to NEW Configuration
Before Answering This Request.

This reminds you to make sure the configuration of the terminal matches the new configuration of the master configuration port. If they do not match, you will be locked out of Print Master and unable to access its functions.

CAUTION: If "Y" is sent before changing the configuration device to the new configuration (baud rate or parity), Print Master will not receive the "Y" response. However, you will be locked out of Print Master. If this occurs, recycle Print Master power. Print Master's configuration will default back to the last saved configuration. You must then re-enter configuration and re-save the configuration of the configuration port.

If you answer "Y" (yes), the new configuration for that port will be stored permanently in non-volatile memory, and Print Master will subsequently power-up at that configuration.

If you answer "N" (no), the new configuration will be stored in RAM, and on the next power-up, Print Master will revert to the previous configuration.

NOTE: The *Y* and *N* responses must be upper case. If a lower case *Y* is entered, Print Master will interpret it as "no" and the changes you have made will not be saved permanently in memory.

Print Master will then respond with a message similar to:

Enter Port Number (5 to 6, 0=Exit), CR:

If you wish to reconfigure another serial port, send that port number followed by <ENTER>. If no additional changes are desired, type 0 (zero) and <ENTER>.

Print Master will now return to the main configuration menu (see *Section 7.3.1*).

7.3.4 ALL 700D, 700E, 700F MODELS -CHANGE PORT LOGICAL NAME

By responding to the Enter request: message at the end of the main configuration menu with "3" (Change Port Logical Name), you may change the logical name for each connected device to a user-defined name. Logical names are simply aids to identifying which devices are connected to which ports. They have no other function.

Print Master will respond with a message similar to:

Enter Port Number (1 to 6, 0=Exit),CR:

Enter the desired port number followed by <ENTER>. For example, if you type "3" and <ENTER> for Port 3, Print Master will respond with:

Port	Logical Name	Port Type	Port Assigt	Printer Assigt
3	Device C	Parall	Computer	0

Enter Logical Name:

Enter the new logical name for Port 3. For example, if you entered "IBM AT", Print Master will respond with:

Port	Logical Name	Port Type	Port Assigt	Printer Assigt
3	Device C	Parall	Computer	0

Enter Port Number (1 to 6, 0=Exit), CR:

If you wish to change the logical name on another port, enter that port number followed by <ENTER> and repeat the above procedure. If no additional changes are desired, type "0" (zero) and <ENTER>. Print Master will save the new logical names permanently in non-volatile memory and return to the main configuration menu (see *Section 7.3.1*).

7.3.5 ALL 700D, 700E, 700F MODELS - SET PORT ASSIGNMENT

By responding to the *Enter Request:* message at the end of the main configuration menu with "4" (Set Port Assignment), you may assign any port as a computer port or a printer port.

NOTE: Port 10 on Models 710E and 710F may not be assigned as a printer port.

Print Master will respond with a message similar to:

Enter Port Number (1 to 6, 0=Exit),CR:

Enter the number of the port that you wish to designate a computer or printer port. For example, if you type "3" and <ENTER> for Port 3, Print Master will respond with:

Port	Logical Name	Port Type	Port Assign	Printer Assign
3	Device C	Parall	Computer	0

Change to Printer or Computer port? (P/C):

Enter capital **P** if you wish this port to be a printer port. Enter capital **C** if you wish this port to be a computer port. For example, if you enter "P", Print Master will respond with:

Port	Logical Name	Port Type	Port Assign	Printer Assign
3	IBM AT	Parall	Printer	0

Number of Printers is.....2
Enter Port Number (1 to 6, 0=Exit), CR:

NOTE: At least one port must always be designated as a printer port. If the port number you enter is the only assigned printer port, Print Master will prevent you from reassigning that port and will prompt you with a message similar to:

```
Cannot Reassign the Only Printer Port  
Enter Port Number (1 to 6, 0=Exit),CR:
```

If you wish to change the assignment of another port, type that port number and <ENTER>, and repeat the above procedure.

When no other port assignment changes are needed, type 0 (zero) and <ENTER>. Print Master will save the new port assignments permanently in non-volatile memory and return to the main configuration menu (see *Section 7.3.1*).

NOTE: When the port assignment is changed for any port, the printer assignment on all computer ports automatically resets to 0 (zero), putting Print Master into contention mode.

7.3.6 ALL 700D, 700E, 700F MODELS -SET INPUT INACTIVITY TIMEOUT

By responding to the *Enter Request:* message at the end of the main configuration menu with "5" (Set Input Inactivity Timeout), you may set the input inactivity timeout. Print Master will automatically disconnect the computer if no characters are received from the computer for the specified timeout period.

Print Master will respond with:

```
Input Inactivity Timeout is.....20 seconds
Enter Timeout (0 to 200), CR.....:
```

Type the number of timeout seconds that you wish from 0 to 200, followed by <ENTER>.

WARNING: If you type <ENTER> only without entering a value, the input inactivity timeout will automatically set to 0 (zero) seconds, disabling the timeout.

CAUTION: Do not set the input inactivity timeout to zero seconds when Printer Select Mode 1 has been selected. Mode 1 recognizes the end of a print job by input inactivity timeout only. It does not recognize a manual disconnect.

Print Master will save the new input inactivity timeout permanently in non-volatile memory and return to the main configuration menu (see *Section 7.3.1*).

7.3.7 ALL 700D, 700E, 700F MODELS -PROGRAM PRINTER SELECT CODE

By responding to the *Enter Request:* message at the end of the main configuration menu with "6" (Program Printer Select Code), you may change the Printer Select Code to a user-defined code. The Printer Select Code consists of any character string from 1 to 8 ASCII characters.

Print Master will respond with:

```
Printer Select Code is.....$PRINTER
Enter Printer Select Code
(0 to 8 Chrs, CR).....:
```

Type the new Printer Select Code, followed by <ENTER> or just <ENTER> for no change.

NOTE: Non-printable characters are acceptable, but they will not appear in the status menu. If you are using the BayTech utility software to select printers, be certain to change the Printer Select Code in the software as well.

Print Master will save the new Printer Select Code permanently in non-volatile memory and return to the main configuration menu (see *Section 7.3.1*).

7.3.8 ALL 700D, 700E, 700F MODELS - SET PRINTER SELECT MODE

By responding to the *Enter Request:* message at the end of the main configuration menu with "7" (Set Printer Select Mode), you may change the method of selecting printers.

Print Master will respond with:

```
Select Printer -  
At the Beginning of Printing Only...1  
Anytime While Printing.....2  
  
Printer Select Mode is.....2  
Enter Printer Select Mode.....:
```

Enter the Printer Select Mode you want. Print Master will save the new Printer Select Mode permanently in non-volatile memory and return to the main configuration menu (see *Section 7.3.1*).

7.3.9 ALL 700D, 700E, 700F MODELS - SET FORM FEED MODE

By responding to the *Enter Request:* message at the end of the main configuration menu with "8" (Set Form Feed Mode), you may select one of four form feed modes.

Print Master will respond with:

```
No Form Feed.....1  
Form Feed at the Beginning of Printing....2  
Form Feed at the End of Printing.....3  
Form Feed at the Beginning and End.....4  
  
Form Feed Mode is.....1  
Enter Form Feed Mode.....:
```

You should then enter the Form Feed Mode you want. Print Master will save the new form feed mode permanently in non-volatile memory and return to the main configuration menu (see *Section 7.3.1*).

7.3.10 ALL 700D, 700E, 700F MODELS - PROGRAM HEADER PAGE MESSAGE

By responding to the Enter request: message at the end of the main configuration menu with "9" (Program Header Page Message), you may enable or disable this message and program its content.

Print Master will respond with:

```
Header Page Message is (OFF):  
This print job is for:
```

```
Enter Header Page Message  
(0 to 80 chrs, Ctrl C = Terminate):
```

Enter the new message, followed by *Control-C*. Note that the message will print on paper exactly as it is placed on the CRT screen.

The message may appear on one line or several lines. If several lines are desired, each line must be ended by *Carriage Return* and *Line Feed (Control-J)*. If no change in the message is desired, send *Control-C* only, and the current message will be retained.

Print Master will respond with:

```
Print Header Page (R/Y/N)?.....:
```

If you enter *R* (repeat), the entire sequence will be repeated, and you may re-enter the Header Page Message. If you enter *Y* (yes), the new Header Page Message will be stored permanently in non-volatile memory and will print on all subsequent print jobs. If you enter *N* (no), the Header Page Message will be disabled and will not print. The new message, however, will be stored permanently in non-volatile memory. Print Master will now return to the main configuration menu (see *Section 7.3.1*).

7.3.11 ALL 700D, 700E, 700F MODELS - EXIT

To exit the configuration mode, send capital **X** in response to the prompt at the end of the main configuration menu, and Print Master will return to the operating mode.

8 MAINTENANCE

Since there are no adjustments and no moving parts in Print Master, preventative maintenance is unnecessary.

If you find it necessary to return Print Master to the factory for warranty work or factory-set changes, follow the procedure listed under *Section 9* for repacking.

Before you ship your unit, please call BayTech to get a Return Authorization number. BayTech cannot accept warranty or no-charge returns without this number.

Ship your unit to the address listed under *Section 10*.

9 REPACKING FOR SHIPPING

If you need to repack your unit for shipping, please choose a heavy cardboard box for packing. Surround your unit with sufficient insulation (a minimum of 2-inches) to withstand the rigors of transport.

Be sure to seal the box securely with strapping or packing tape. Masking tape or cellophane tape is not recommended.

If you are returning your unit for warranty work or repair, please call BayTech to get a Return Authorization number. BayTech cannot accept no-charge returns without this number. Please refer to *Section 10*.

10 TECHNICAL SUPPORT

In the event that you have problems with your Print Master, BayTech has a staff of applications engineers on duty to assist you from 7 am to 6 pm (CST or CDT), Monday through Friday.

IMPORTANT: Before you call BayTech Technical Support, please check the Troubleshooting section of this manual (see *Appendix C*).

When you call BayTech Technical Support, please have the following information available to help the applications engineers answer your questions more efficiently:

1. Identify which Print Master you are using and have the serial number (located on the back of the unit) handy.
2. Identify what computers, printers or other peripherals you have connected to Print Master.
3. Identify any special equipment you are using (for example, in-line spoolers, networks, software drivers, etc.).
4. Identify what cables you are using, what the lengths of the cables are, and who sold you the cables.
5. Identify any special options you may have ordered with your Print Master.
6. Identify the software packages you are using.
7. If possible, have a print-out of Print Master's configuration status ready when you call.

IMPORTANT: Always call BayTech before dismantling your equipment and returning Print Master to BayTech for repair.

If you have questions that are not answered in this manual, please contact BayTech Technical Support for assistance.

Bay Technical Associates, Inc.
200 N. Second Street, P.O. Box 387
Bay Saint Louis, Mississippi 39520 U.S.A.

Phone: 228/467-8231 or 800/523-2702

FAX: 228/467-4551

Web Site: www.baytechdcd.com

11 FEDERAL COMMUNICATIONS COMMISSION RADIO FREQUENCY INTERFACE STATEMENT*

This equipment generates, uses, and can radiate radio frequency energy; and, if not installed and used properly (that is, in strict accordance with the manufacturer's instructions) may cause interference to radio and television reception. The equipment has been type tested and found to comply within the limits for a Class A computing device in accordance with the specifications in Subpart J of Part 15 of FCC rules, which are designed to provide reasonable protection against such interference in a residential installation. However, there is no guarantee that interference to radio or television reception will not occur in a particular installation. If this equipment does cause interference to radio or television reception, which can be determined by turning the equipment off and on, the user is encouraged to try to correct the interference by one or more of the following measures.

1. Reorient the receiving antenna.
2. Relocate the computer equipment with respect to the receiver.
3. Move the computer away from the receiver.
4. Plug the computer into a different outlet so that computer and receiver are on different branch circuits.

If necessary, the user should consult the dealer or an experienced radio/television technician for additional suggestions.

The Federal Communications Commission has prepared a booklet entitled "How to Identify and Resolve Radio - TV Interference Problems" which may be helpful to you. This booklet (stock #004-000-00345-4) may be purchased from the Superintendent of Documents, U.S. Government Printing Office, Washington, D.C. 20402.

**Use of a shielded interface cable is required to comply within the Class A limits in Subpart J of Part 15 of FCC rules.*

APPENDIX A

RECOMMENDED CABLING

A.1 BETWEEN IBM PC, IBM XT, IBM PS/2 AND PRINT MASTER (DB-25)

RECOMMENDED CABLING USING HARDWARE OR XON/XOFF HANDSHAKING

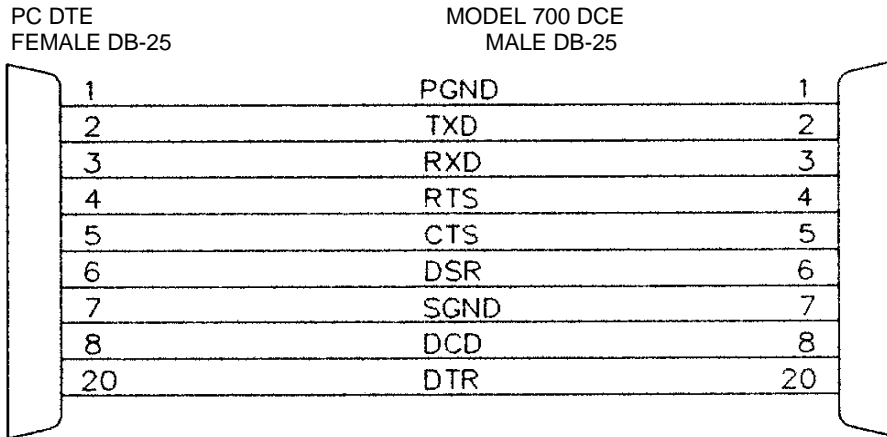

MINIMUM CABLING USING XON/XOFF HANDSHAKING

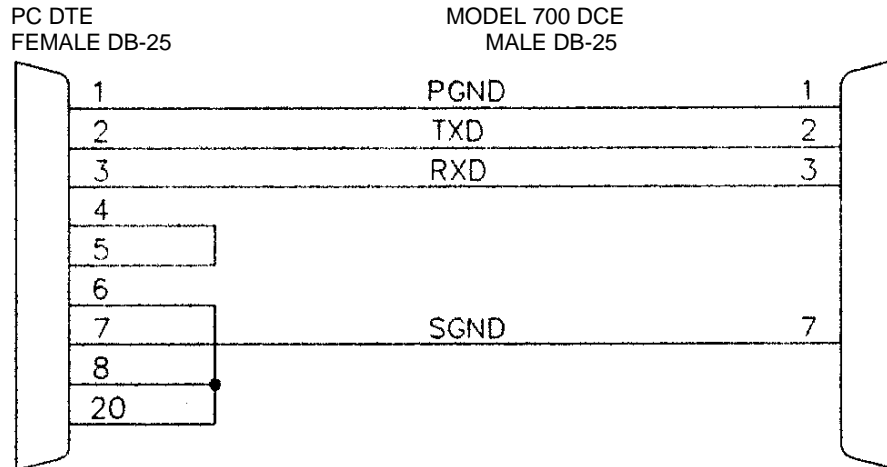

MINIMUM CABLING USING HARDWARE HANDSHAKING

PC DTE
FEMALE DB-25

MODEL 700 DCE
MALE DB-25

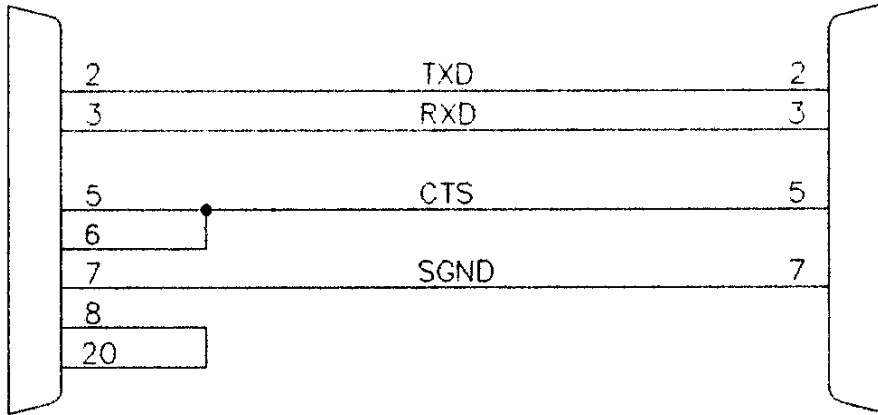

A.2 BETWEEN IBM AT AND PRINT MASTER (DE-9)

RECOMMENDED CABLING USING HARDWARE OR XON/XOFF HANDSHAKING

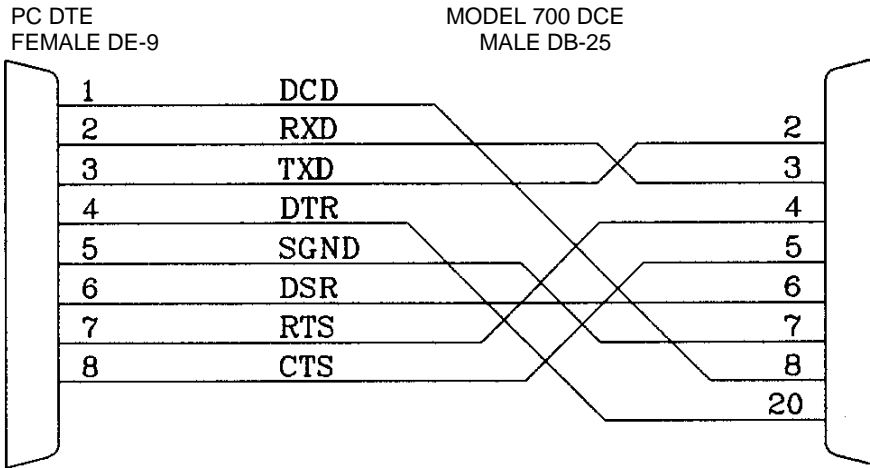

MINIMUM CABLING USING XON/XOFF HANDSHAKING

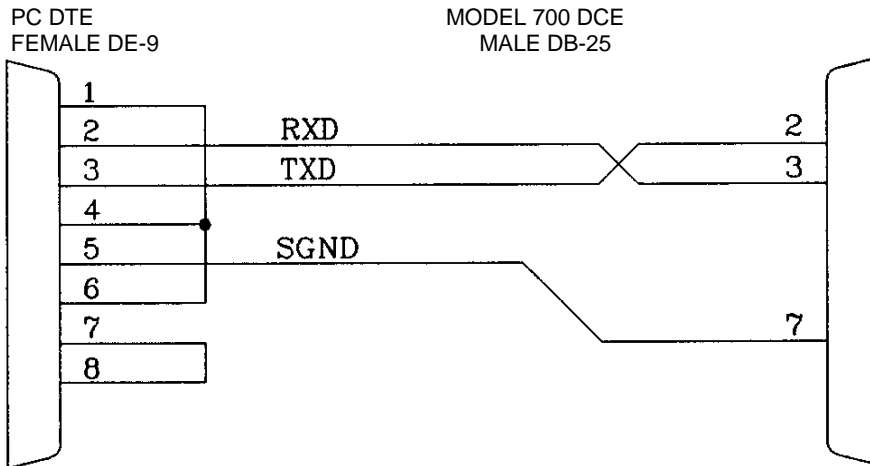

MINIMUM CABLING USING HARDWARE HANDSHAKING

PC DTE
FEMALE DE-9

MODEL 700 DCE
MALE DB-25

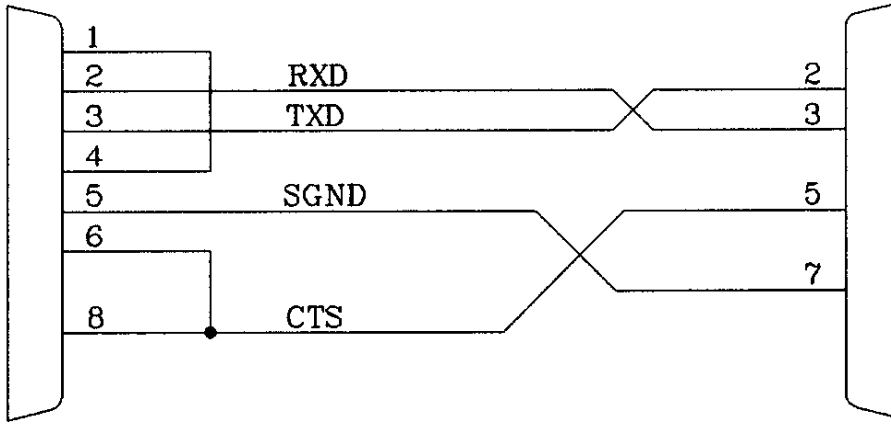

A.3 BETWEEN PRINT MASTER AND HEWLETT PACKARD LASERJET

RECOMMENDED CABLING USING HARDWARE OR XON/XOFF HANDSHAKING

MODEL 700 DCE
MALE DB-25

HP LASERJET
FEMALE DB-25

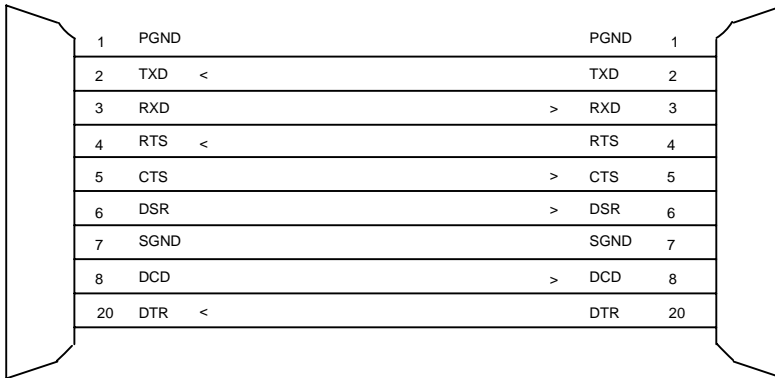

MINIMUM CABLING USING HARDWARE OR XON/XOFF HANDSHAKING

MODEL 700 DCE
MALE DB-25

HP LASERJET
FEMALE DB-25

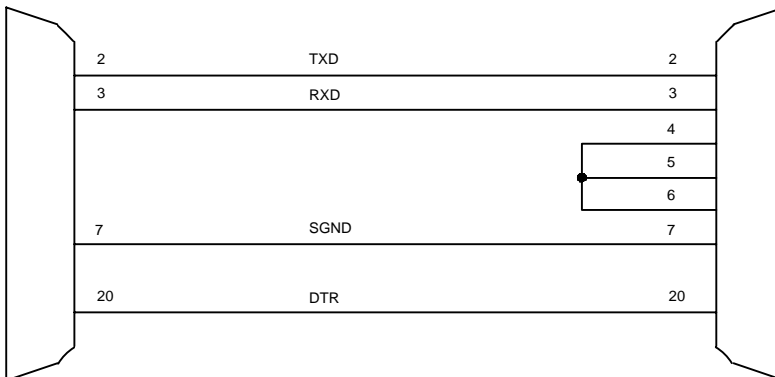

NOTE: You may eliminate the Pin 20 to Pin 20 connection if you wish to use 3 wires and XON/XOFF handshaking only. You may use the pinouts above for any HP Draft Master plotter.

A.4 BETWEEN PRINT MASTER AND ANY CENTRONICS PRINTER

PRINT MASTER
MALE DB-25

PRINTER 36-PIN
CENTRONICS

1		STROBE	>	1
2		DATA 0	>	2
3		DATA 1	>	3
4		DATA 2	>	4
5		DATA 3	>	5
6		DATA 4	>	6
7		DATA 5	>	7
8		DATA 6	>	8
9		DATA 7	>	9
10	<	ACKNOWLEDGE		10
11	<	BUSY		11
12	<	PAPER OUT		12
13	<	SELECT		13
14		AUTO FEED/OV	>	14
15	<	ERROR		32
16		INIT PRINTER	>	31
17		SELECT INPUT/OV	>	36
18		OV		19
19		OV		20
20		OV		21
21		OV		22
22		OV		23
23		OV		24
24		OV		25
25		OV		26

A.5 700C MODELS - MODULAR CABLING

COMPUTER INTERFACE

To interface your computers or terminals to Print Master refer to the RJ-45 adapter drawings below. Refer to *Figure 6* if your computers or terminals have DB-25 male connectors. Refer to *Figure 7* if your computers have DE-9 male connectors.

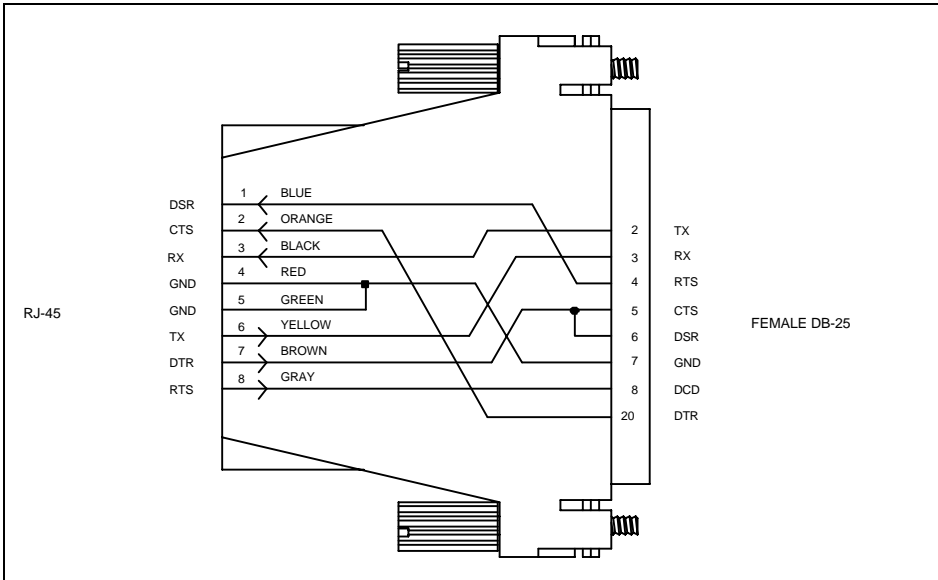

Figure 6: XT, PS/2 Computer/Terminal Adapter
BayTech Part No. 25FRJ45PC

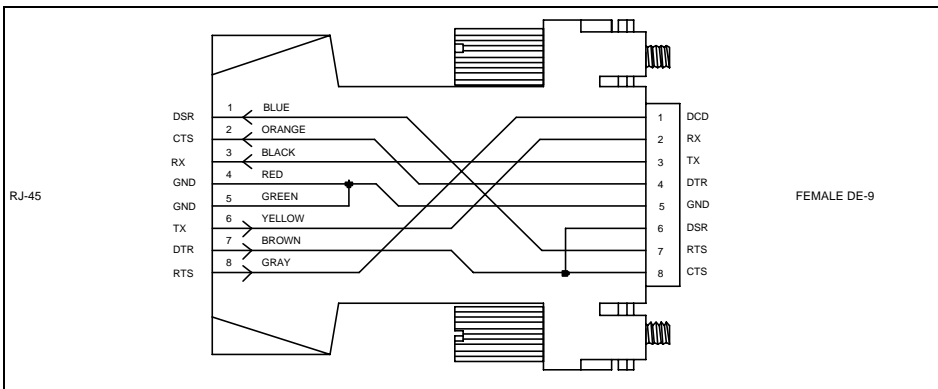

Figure 7: AT Computer Adapter
BayTech Part No. 9FRJ45PC

PRINTER/PLOTTER INTERFACE

To interface your EIA-232 serial printers or plotters to Print Master refer to *Figure 8*.

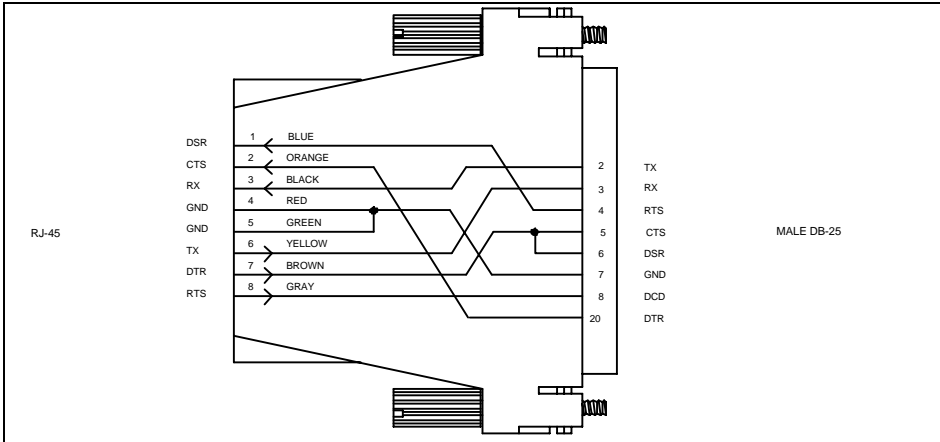

Figure 8: Printer/Plotter Adapter
BayTech Part No. 25MRJ45PR

IMPORTANT: When modular connectors are used as shown in Figures 6 - 8 above, crossed RJ-45 cables are required. The RJ-45 cable, between Print Master and your connected equipment must be crossed. See the cable diagram below.

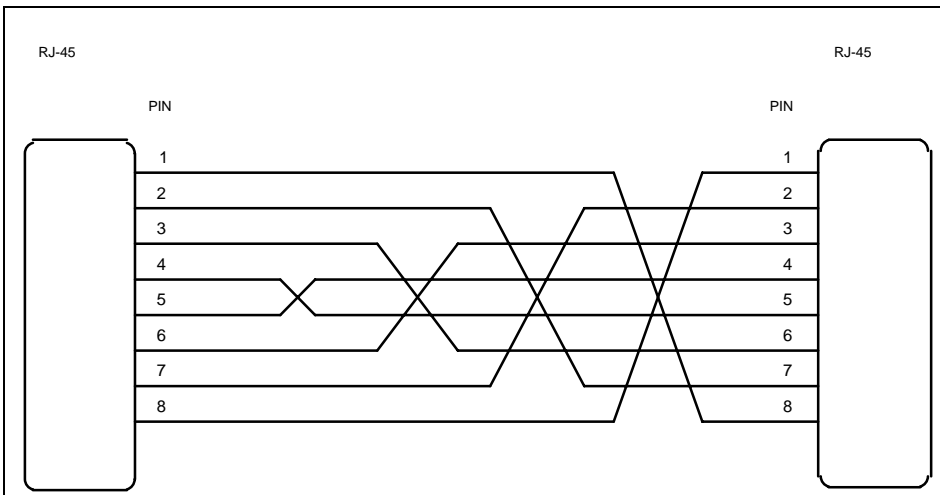

Figure 9: Crossed RJ-45 Cable
BayTech Part No. RJ08X010 (10 feet)

APPENDIX B

OPTION 19 - CASCADE FEATURE FOR MODELS 710C, 710E, 710F

Option 19 allows up to nine (9) Print Master 710C, 710E or 710F models to be cascaded allowing you to increase the number of available ports. All 710 models with Option 19 may be cascaded together. The primary difference in 710 models with Option 19 versus standard 710 models is the incorporation of a *Unit ID Number*. The unit ID number is used to direct a print job to a specific 710 model in a cascaded chain of units and is very similar to the printer assignment number described in *Section 6.2.2*. Ports 9 and 10 of each unit are reserved as cascading ports. Port 9 or Port 10 may be used as computer ports (if the port is available), but have the following limitations:

1. XON/XOFF is not available on these ports.
2. The Header Page Message is not generated on these ports.
3. On the Print Master 710C only, Ports 9 and 10 will always default to the same configuration.
4. Under certain conditions, a Printer Select Code is generated at Port 9 or Port 10 and will be passed to a computer if it is connected to the port.
5. Ports 9 and 10 do not feature a minimum 3-character print job.

The steps to installing and operating 710 models with Option 19 involve configuring each unit (see *Appendix B.1*), cabling the units together (see *Appendix B.2*), and operation (see *Appendix B.3*).

B.1 OPTION 19 - CONFIGURATION

Print Masters equipped with Option 19 (Cascade Option) are configured exactly as described in *Section 7.2* or *Section 7.3* of this manual with the exception of SET UNIT ID NUMBER. Each 710 Print Master with Option 19 is configured individually through Port 10. During operation, Port 10 is typically used to cascade to another Print Master. Therefore, you should make the necessary configuration changes to each unit prior to cabling the units together. Please review the following configuration notes for cascading 710 models.

1. Each 710 model must be assigned a unique Unit ID Number (see *Appendix B.1.3*). This number is used to direct a print job to a specific unit in the cascaded chain. Port 10 of a 710 having a lower Unit ID Number will connect to Port 9 of a 710 having a higher Unit ID Number. For example, if you have two 710s with Unit ID Numbers of 1 and 2 respectively, Port 10 of Unit 1 would connect to Port 9 of Unit 2.
2. The serial configuration (i.e., baud rate, word size, etc.) of cascading ports on interconnected units must match. Following our example in NOTE 1 above, the serial configuration of Port 10 on Unit 1 must match that of Port 9 on Unit 2.

On Print Master 710C only, Ports 9 and 10 will always be set to the same configuration. If you change the configuration of Port 9, Port 10 will match this configuration automatically and vice versa. This is not applicable on the 710E or 710F units.

3. Cascaded 710 units must be configured with the same Printer Select Code.
4. Cascaded units should operate in Printer Select Mode 2.
5. If the number of printers is changed on a unit, the Unit ID Assignment Number on all computer ports will automatically reset to that unit's ID number.

B.1.1 OPTION 19 - MAIN CONFIGURATION MENU

When the computer connected to Port 10 of a 710 model with Option 19 accesses the configuration mode by sending **Control-T** followed by capital **C**, Print Master will respond with an identification block and main configuration menu similar to the following:

```
Bay Technical Associates
Model 710E Print Master with Option 19
Copyright 1986,1987,1988, 1989
Revision 3.00
Total Memory : 0512K Bytes

Status.....1
Set Serial Port Configuration.....2
Change Port Logical Name.....3
Set Port Assignment.....4
Set Input Inactivity Timeout.....5
Program Printer Select Code.....6
Set Printer Select Mode.....7
Set Form Feed Mode.....8
Program Header Page Message.....9
Set Unit I.D. Number.....A
Exit.....X
```

Enter Request:

All listings in the above menu except Set Unit I.D. Number are configured as described in *Section 7* of this manual. The Set Unit I.D. Number selection is described in *Appendix B.1.3*.

NOTE: On the Model 710C, since the main configuration menu differs slightly from the Models 710E and 710F, the *Set Unit I.D. Number* will be listed as selection 9.

Menu selection is case sensitive. It is recommended that your keyboard be in the CAPS LOCK position.

B.1.2OPTION 19 - CONFIGURATION STATUS

By responding to the Enter request: message at the end of the main configuration menu with "1" (Status), you may review the current configuration status of Print Master. Print Master will respond with menus similar to the following:

Port	Logical Name	Port Type	Port Assight	Unit Assn	Printer Assn
1	Device A	Parall	Printer	1	0
2	Device B	Serial	Computer	1	0
3	Device C	Serial	Computer	1	3
4	Device D	Parall	Computer	1	0
5	Device E	Serial	Computer	1	0
6	Device F	Serial	Computer	1	0
7	Device G	Serial	Computer	1	0
8	Device H	Serial	Computer	1	0
9	Device I	Serial	Cascading	1	0
10	Device J	Serial	Cascading	1	0

Strike any Key to Continue, or X to Exit

Port	Baud Rate	Word Size	Stop Bits	Pariity	Xon/Xoff
2	9600	8	1	None	Off
3	9600	8	1	None	Off
4	9600	8	1	None	Off
5	9600	8	1	None	Off
6	9600	8	1	None	Off
7	9600	8	1	None	Off
8	9600	8	1	None	Off
9	9600	8	1	None	Off
10	9600	8	1	None	Off

Strike any Key to Continue, or X to Exit

Time Out is.....20 Seconds
 Number of Printers is.....1
 Printer Select Code is.....\$PRINTER
 Printer Select Mode is.....2
 Form Feed Mode is.....1
 Header Page Message is (OFF):
 This Print Job is for :
 Unit Identification Number is1
 Strike any Key to Continue, or X to Exit

B.1.3OPTION 19 - SET UNIT ID NUMBER

By responding to the Enter request: message at the end of the main configuration menu with "A" for models 710E and 710F or "9" for model 710C (Set Unit I.D. Number), you may set the Unit ID number which is used to determine which unit in the cascaded chain a print job will be sent to.

NOTE: Units do not need to be numbered in numerical sequence. For example, if three Print Master units are being cascaded, they can be identified as Units 1, 2, 3 or Units 4, 6, 8, Units 1, 6, 9, etc.. However, two units cannot be configured with the same Unit ID Number.

Print Master will respond with:

Unit Identification Number is.....1
Enter new Unit Number (1 to 9).....:

Enter the desired Unit ID Number. Print Master will save the Unit ID Number permanently in non-volatile memory and return to the main configuration menu (see *Appendix B.1.3*).

B.2 OPTION 19 - CABLING

To cable Print Masters equipped with Option 19 together, connect Port 10 of a 710 having a lower Unit ID Number to port 9 of a 710 having a higher Unit ID Number with a male-to-male crossed cable (BayTech part number MM09XYYY, where YYY is the required length). The required pinout is shown in *Figure 3* on page 18.

B.3 OPTION 19 - SHARING OF PRINTERS

Cascaded units power up from the factory in contention mode, which allows any of the computers connected to a particular unit to contend for any of the printers connected to that same unit. These computers will not contend for printers connected to other Print Master units when in power-up contention mode.

Printer selection is accomplished by sending a printer select sequence consisting of the Printer Select Code followed by a two-digit number. This two digit number consists of the desired Unit ID Number followed by the desired printer port number on that unit.

NOTE: *\$PRINTER* is the factory default Printer Select Code. Other codes may be programmed, but all cascaded Print Master units must be configured to have the same Printer Select Code.

EXAMPLE 1: If a computer connected to unit number 1 wishes to print to a printer connected to port 5 of unit number 4, the computer would send **\$PRINTER45**.

EXAMPLE 2: If a computer connected to Unit number 2 wishes to send data to any printer connected to Unit 3 (contention mode), the computer would send **\$PRINTER30**.

EXAMPLE 3: If a computer connected to Unit number 4 wishes to output data to the printer connected to Port 1 of the same unit, the computer would send **\$PRINTER41**.

The Unit ID Number and the printer port number then become the default unit and printer assignment numbers for that computer. All subsequent print jobs sent without a printer select sequence will be sent to this unit/printer port by default. If you desire to send print jobs to the same printer, the Printer Select Code, Unit ID Number, and printer port number do not need to be sent again.

If you wish to select another printer on any unit without changing the default unit and port assignment numbers, send the Printer Select Code, capital **T**, the desired unit ID number, and the desired printer port number. The next print job sent will be sent to the temporary unit/printer. Subsequent print jobs without a Printer Select Code will be sent to the default unit/printer.

If you send an invalid printer select sequence, various conditions will determine where the print job is sent. In any case, the print job should be immediately resent with a valid Printer Select Code.

The clear buffer command described in *Section 6.2.6* will only clear the buffer on the unit to which the computer sending the data is connected. If all or part of the data has already been passed to the buffer of another cascaded unit, that buffer will not be cleared.

The utility software may be used with Option 19 units to send the printer select sequence.

APPENDIX C

TROUBLESHOOTING

Please check this troubleshooting guide before calling BayTech Tech Support.

NOTE: This troubleshooting guide is geared towards the IBM PC family and compatibles. The term "PC" as used below refers to any IBM PC, AT, XT or compatible.

PROBLEM: DATA DOES NOT PRINT

SYMPTOM: NO PORT LEDs ILLUMINATE

CAUSE: PC serial cable or COM port.

SOLUTIONS:

- 1) Check cabling between PC and Print Master.
- 2) Check handshaking lines using TERM program. All lines (except DCD which is not used) should be high. If lines are high, turn Print Master off. You should notice CTS and DSR lines go low. If they do not go low, there is a good chance cable is incorrect (see *Appendix A*). Typing characters from TERM should illuminate PC LED on Print Master.
- 3) Check installation procedures for PC's serial port. COM1 must generate an interrupt on IRQ4 (COM2 on IRQ3). Also, check any jumpers for defining port configuration which should be jumpered for DTE, not DCE.

CAUSE: PC parallel cable.

SOLUTION: Check cable's continuity and pin configuration.

CAUSE: Print Master is connected to non-designated COM port.

SOLUTION: Make sure Print Master is connected to designated PC COM port. Check using TERM program. Turn Print Master off and you should **not** see CTS/DSR lines toggle if you are on a non-designated COM port.

CAUSE: PC is connected to Print Master port which is configured as a printer port.

SOLUTION: Enter Print Master's configuration mode and in the Status menu, check the port's assignment.

CAUSE: LPTX not rerouted to COMX port for PC serial communication.

SOLUTION: Reroute LPT port as follows:
MODE LPTX:=COMX (X = 1, 2 or 3)

CAUSE: Print Master is in configuration mode.

SOLUTION: Exit configuration mode or recycle power.

PROBLEM: DATA DOES NOT PRINT

SYMPTOM: PC AND PRINTER PORT LEDs ILLUMINATE

CAUSE: Printer cable.

SOLUTION: Use the correct parallel or serial cable between Print Master and printer (see *Appendix A*).

CAUSE: Printer is off-line.

SOLUTION: Make sure printer is on-line

CAUSE: Serial parameters do not match between Print Master and computer or printer.

SOLUTION: Verify the serial parameters match between the computer and Print Master and between Print Master and the printer.

SYMPTOM: ON POWER-UP, ALL LEDs COME ON AND STAY ON

CAUSE: Print Master failure.

SOLUTION: Call BayTech technical support.

PROBLEM: PRINTS GARBAGE

SYMPTOM: MISSING CHARACTERS

CAUSE: Incorrect printer cable type.

SOLUTION: See *Appendix A* for correct pinouts between Print Master and printer. Check handshaking. A way to check is to force an error condition at the printer (i.e. remove paper tray from laser printer or turn off-line with power still applied). Send print job to printer. If printer LED goes off, you can conclude no handshaking was done. If your printer is connected in serial, check printer's configuration and match handshaking (i.e., you must use CTS/DTR or XON/XOFF for both Print Master and printer). Also check pin 20 (DTR) on serial ports or pin 11 on parallel ports for continuity by using an ohm meter to check resistance from end to end.

CAUSE: Parallel cable length.

SOLUTION: Parallel cable should not exceed 15 feet. Use shorter length or higher-quality cable.

CAUSE: Configuration problem.

SOLUTION: Check baud rate, word size, stop bits and parity on serial ports. Verify that these parameters match those of your equipment.

SYMPTOM: RANDOM GARBAGE CHARACTERS

CAUSE: Serial port configuration.

SOLUTION: In Print Master's configuration mode, match baud rates, word size, stop bits, parity, and handshaking with the connected serial device(s).

CAUSE: Cable length.

SOLUTION: If using serial cable, length should not exceed 150 feet. If using parallel cable, length should not exceed 15 feet. Use shorter cable.

PROBLEM: CANNOT CONFIGURE PRINT MASTER

SYMPTOM: CONTROL-T AND CAPITAL C SENT IN DUMB TERMINAL MODE DOES NOT INVOKE CONFIGURATION MENUS.

CAUSE: Cable.

SOLUTION: Use correct serial cable between PC and Print Master. Check handshaking lines in TERM program. On 706A unit, check parallel cable between Print Master and printer.

CAUSE: Serial port configuration.

SOLUTION: Match baud rate, word size, stop bits, parity and handshaking lines between Print Master and PC. This can be done using TERM program.

CAUSE: Port selection.

SOLUTION: Be sure PC COM port is connected to configuration port of Print Master.

CAUSE: Software.

SOLUTION: Use dumb terminal or a PC running a terminal emulation program (e.g, TERM supplied by BayTech or another program such as PC Plus).

CAUSE: User activity.

SOLUTION: Wait until current activity between PC and printer is completed. There should be no red LEDs illuminated when trying to configure.

CAUSE: Bad PC COM port.

SOLUTION: Try a different COM port or PC.

CAUSE: PC serial card uses incorrect interrupt. The TERM program requires that COM1 use IRQ4 and that COM2 use IRQ3

SOLUTION: Reconfigure serial card, use different serial card or different terminal emulation program.

PROBLEM: CANNOT SELECT PRINTER

CAUSE: Port selection.

SOLUTION: Printer Select Code may be sent out on wrong port (e.g. Printer Select Code is going out COM1 and Print Master is connected to COM2). Also make sure selected port is designated as a printer port and not as a computer port.

CAUSE: Improper Printer Select Code.

SOLUTION: Match Printer Select Code you are sending to Printer Select Code specified in configuration mode. Check case of Printer Select Code (upper or lower). Also, remove any spaces between Printer Select Code and port number.

CAUSE: You are in Printer Select Mode 1 with zero (0) timeout.

SOLUTION: Switch to Printer Select Mode 2 or increase timeout, both via configuration mode.

NOTE: Any select sequence will not be recognized after 16 characters in Printer Select Mode 1.

SYMPTOM: SOME SORT OF PRINTER SELECT CODE PRINTS ON DOCUMENT.

CAUSE: Printer Select Code sent does not match Printer Select Code configured in Print Master.

SOLUTION: Match the Printer Select Code sent exactly with that configured in Print Master.

PROBLEM: CANNOT SELECT PRINTER DURING PRINT JOB

CAUSE: You are using Printer Select Mode 1 (printer selection at beginning of printing only).

SOLUTION: Switch to Printer Select Mode 2 in configuration (printer selection anytime while printing).

PROBLEM: PRINT JOB SWITCHES PRINTERS IN THE MIDDLE OF A PRINT JOB

CAUSE: Timeout period too short.

SOLUTION: Increase input inactivity timeout period via configuration mode.

CAUSE: Port select sequence sent in the middle of the document.

SOLUTION: Verify that Port Select Code is not contained in the document. Do not activate the hot key software while the print job is still being sent from the computer

CAUSE: Characters used in Printer Select Code are too common and may inadvertently appear somewhere in print job.

SOLUTION: Change Printer Select Code to a unique character sequence.

PROBLEM: PRINT JOBS INTERMIX

CAUSE: Timeout period is too short.

SOLUTION: Increase input inactivity timeout period via configuration mode.

PROBLEM: PRINT MASTER DOES NOT TIMEOUT

CAUSE: Timeout is set to zero (0).

SOLUTION: Increase input inactivity timeout period via configuration mode.

PROBLEM: PRINT JOBS ARE LOST WHEN MORE THAN ONE USER IS SENDING PRINT JOBS.

CAUSE: Printer port is not connected to a printer or is connected to a powered-down printer. Data sent to a non-connected printer port or a powered-down printer will be lost.

SOLUTION: Select a printer that is physically connected and powered on.

NOTE: Printer ports that do not have a printer physically connected should be reconfigured to a computer port.

PROBLEM: HOT KEY SOFTWARE HANGS UP PC WHEN EXECUTED.

CAUSE: LPTX not rerouted for serial communication.

SOLUTION: Reroute LPTX using this command:

MODE LPTX:=COMX. X=1, 2 or 3.

CAUSE: Floating condition on DSR or CTS lines.

SOLUTION: Use the TERM program to check handshaking lines. Power down Print Master. If DSR, DCD and CTS lines do not toggle, check computer cable (see *Appendix A*).

APPENDIX D

INDEX

A_____

Antenna 77
ASCII 4, 22, 31, 37, 39, 45, 48, 57, 60, 71
Asynchronous 3
Autoexec 9, 13, 14

B_____

Baud rate 2-4, 8, 12, 23, 48, 49, 52-54, 60, 61, 64, 65, 66, 87,
96, 97
Buffer 1, 4, 16, 24, 25, 27-30, 32, 34-37, 92

C_____

Cable 8, 15, 17, 49, 50, 61, 62, 77, 85, 91, 93, 95, 96, 97, 101
Cables 8, 15, 17, 19, 75, 85
Cabling 2, 8, 15, 16, 18-20, 38, 78-82, 84, 86, 87, 91, 93
Cascade 86, 87
Cascaded 86, 87, 90-92
Cascading 86, 87, 89
Cascading ports 86, 87
Case sensitive 40, 50, 88
Centronics 1, 3, 8, 15, 83
Clear buffer command 28-30, 92
CLR 30
COMX 94, 101
Configuration 2-4, 6-8, 12, 14, 20, 21, 23, 24, 38, 39, 40-73,
75, 86-90, 93, 94, 96-100
Configuration mode 2, 7, 8, 12, 21, 24, 38, 47, 48, 59, 60, 73,
88, 94, 97-100
Configuration port 4, 12, 21, 38, 48, 53, 54, 60, 65, 66, 97
Configuration procedure 38, 48, 60
Configuration status 41, 75, 89
Contention mode 26, 27, 44, 56, 69, 91

Control-C 47, 59, 73
Control-T 39, 40, 48, 50, 60, 62, 88, 97
CTS 5, 16, 17, 19, 29, 34, 36, 49, 50, 61, 62, 93, 94, 96, 101

D_____

Data Communication Equipment 16
Data flow control 20, 34
Data Terminal Equipment 16
DB-25 5, 8, 15, 16, 78-84
DCD 16, 17, 49, 50, 61, 62, 93, 101
DCE 5, 8, 16, 17, 78-82, 93
Dimensions 5
Diskette 2, 9-11, 49, 61
DOS 9, 13, 14, 31, 32
DSR 16, 17, 19, 49, 50, 61, 62, 93, 94, 101
DTE 16, 17, 78-81, 93
DTR 5, 16, 17, 19, 34-37, 49, 50, 61, 62, 96
Dumb Terminal 48, 49, 60, 61, 97, 98
Dynamically allocated buffer 28

E_____

EIA 1, 3, 15-17, 19, 85
EIA-232C 3
Emulation 48-50, 60-62, 98
End of a print job 43, 55, 70
Ending a print job 25, 28
Environment 5
Eprom 12
Error condition 96

F _____

Factory default 7, 9, 14, 20-24, 33, 91

FAX 76

FCC 77

Floating condition 101

Form feed mode 2-4, 12, 20, 23, 40, 41, 46, 50, 51, 58, 62, 63,
72, 88, 89

Full duplex communication 3, 25, 32, 35, 37, 49, 61

G,H _____

GND 19

Guarantee 77

Handshaking 5, 17, 32, 34, 36, 49, 50, 61, 62, 78, 79, 80-82,
93, 96, 97, 101

Header page message 2-4, 12, 20, 24, 40, 41, 47, 50, 51, 59,
62, 63, 73, 86, 88, 89

Hewlett Packard 82

Hewlett Packard LaserJet 82

I _____

IBM 3, 2, 15, 16, 31, 38, 49, 61, 67, 68, 78, 80, 93

In-line spoolers 75

Input inactivity timeout 2-4, 12, 20, 23, 28-30, 32, 33, 40, 41,
43, 50, 51, 55, 62, 63, 70, 88, 99, 100

Intermix 100

J,K,L_____

Jumpers 93

Laserjet 3, 2, 37, 42, 82

LED 5, 12, 20, 33, 39, 48, 60, 93, 96

LEDs 5, 33, 39, 48, 60, 93, 95, 98

Logical name 3, 4, 12, 20, 24, 40-42, 52-54, 62, 63, 67, 88

LPT 94

LPTx 9, 13, 94, 101

M_____

Main configuration menu 39-48, 50-52, 54-60, 62, 63, 64,
66-73, 88-90

Maintenance 74

Menu 2, 4, 9, 11, 39-73, 88-90, 94

Minimum size print job 4, 25, 30

Missing characters 96

MS BASIC 38, 39

N,O,P _____

Non-printable characters 45, 57, 71
Non-volatile memory 2, 4, 27, 42-47, 54-59, 66, 67, 69-73, 90
Number of printers 20, 21, 24, 26, 40, 41, 44, 50, 51, 56, 63, 68, 87, 89
Ohm meter 96
Parity 2-4, 8, 12, 23, 48, 49, 51-54, 60, 61, 63-66, 89, 96, 97
Parsend 8, 38, 39
PC COM port 49, 61, 94, 97, 98
Pinout 20, 91
Port assignment 2-4, 7, 8, 20, 21, 24, 26, 52, 62, 63, 68, 69, 88, 92
Port logical name 4, 12, 20, 62, 63, 67, 88
Port selection 9, 25, 31, 97, 98
Power switch 12
Power-on 12
Power-up default configuration 3, 4
Printer assignment 26, 44, 56, 69, 86, 92
Printer assignment number 26, 44, 56, 86
Printer contention 27, 44, 56
Printer contention mode 44, 56
Printer port 3, 4, 7, 9, 12, 21, 22, 24, 26, 27, 29, 31, 33-37, 41, 43, 51, 68, 69, 91, 92, 94, 95, 98, 100
Printer port number 22, 26, 27, 29, 31, 43, 91, 92
Printer select code 2-4, 20, 22, 26-30, 40, 41, 43, 45, 50, 51, 57, 62, 63, 71, 86-89, 91, 92, 98-100
Printer select mode 2-4, 20, 22, 27-30, 40, 41, 43, 46, 50, 51, 55, 58, 62, 63, 70, 72, 87, 88, 89, 99
Printer selection 4, 9, 11, 27, 91, 99
Printer sharing 2, 20, 24, 25
Protective Ground 16, 17

Q,R_____

Queued 28
Rack-mount 5
RAM 54, 66
Ramexec 9, 11, 13, 14
Readme 9, 11, 13
Recommended cabling 15, 18, 78, 80, 82
Repacking 74
Return authorization 74
Returns 74
RJ-45 5, 15, 19, 84, 85
RTS 16, 17, 19, 49, 50, 61, 62
RX 16, 17, 19

S_____

Serial number 75
Serial port configuration 2, 8, 14, 20, 23, 50-52, 62-64, 88, 97
Setup 12, 13
SGND 16, 17
Signal ground 16, 17, 19
Software drivers 75
Specifications 3, 23, 77
Standard TTL levels 15
Status 40, 41, 45, 50-53, 57, 62-65, 71, 75, 88, 89, 94
Stop bits 2-4, 8, 23, 49, 52-54, 61, 64, 65, 96, 97
Strobe 15

T_____

Tech support 93

Technical Support 9, 75, 76, 95

Television 77

Telex 76

Term 8, 48-50, 60-62, 93, 94, 97, 98, 101

Terminal emulation program 48-50, 60-62, 98

Time-out 39, 55

Timeout 2-4, 12, 20, 23, 28-30, 32, 33, 40, 41, 43, 50, 51, 55,
60, 62, 63, 70, 88, 99, 100

Troubleshooting 75, 93

Tx 16, 17, 19

U,V,W_____

User-programmable 4, 20

Warranty 5, 74

Word size 2-4, 8, 12, 23, 48, 49, 52-54, 60, 61, 64, 65, 87, 96,
97

WordStar 3, 32

X,Y,Z_____

XON/XOFF 2-5, 8, 12, 17, 23, 36, 48, 52-54, 60, 64, 65, 78,
80, 82, 86, 96

XON/XOFF handshaking 36, 78, 80, 82

OTHER BAYTECH PRODUCTS

Print Master 700 Series printer controllers are made in several different configurations satisfying various interface requirements. Each unit allows computers to share, select and/or contend for printers easily and economically, without switching cables. The internal buffering system allows simultaneous, high-speed input from all connected computers and output to all printers. Models come in six, eight, and ten port sizes. All have a 1 MB, dynamically allocated buffer that may be expanded to 2 MB. The **706A** and **708A** all parallel port models feature super fast throughput (up to 33,000 characters per second) and an expandable buffer size up to 4 MB.

Print Master II 800 Series peripheral sharing devices connect between your computers, printers, plotters, modems and other peripherals. These models allow any of your computers to access any of your peripherals -- and talk to other computers so files can be transferred and data shared. Plus, a built-in buffer spools output data until your peripherals can receive it, freeing your computers to go on to other tasks. Models come in four, eight, and ten port sizes. Four port models have a 1 MB standard buffer which is expandable to 2 MB. Eight and ten port models have a 256 KB buffer which may be increased to 1.2 MB.

Model 24SII DES Data Exchange System is the fastest peripheral sharing solution available with throughput speeds up to 60,000 characters per second. The total number of ports may be expanded from 4 to 24 ports using 4-port I/O modules. Any port can be configured as an input or output port. The standard 1.0 MB buffer can be increased to 16 MB by user installed memory packages. Plus, using popular communications software, this unit allows for computer to computer high speed data transfer as well as modem sharing.

LaserShare is an intelligent printer controller that allows up to four or eight computers to send data to a single HP LaserJet Series II, IID, III, IIID, Brother HL8e* and HL8v*, or Wang LDP8 laser printer.

LaserShare MIO installs into the HP LaserJet Series IIISi, Series 4, and Series 4SI and will support serial speeds up to 460K bps.

LaserShare connects directly into the optional I/O or MIO slot of the laser printer. Power is taken directly from the laser printer so there is no need for a power cord. LaserShare and LaserShare MIO can accept data from all ports simultaneously. Print jobs are printed on a first-in first-out basis. All LaserShare models come standard with a buffer that can range from 256K to 4MB. The buffer on LaserShare MIO models may range from 1MB to 4MB. **LaserShare 4C** and **LaserShare 4C MIO** come with four EIA-232C serial ports.

LaserShare 8C and **LaserShare 8C MIO** come with eight serial ports, **LaserShare 4E** comes with two parallel and two serial ports, and **LaserShare 4A** and **LaserShare 4A MIO** come with four parallel ports.

* The LaserShare device for the Brother HL8e and HL8v is referred to as **LaserShare 4CB**. This device is available with four (4) serial computer ports and a fixed buffer size of 256KB.

The BayTech **PS-4A**, **PS-4C**, and **PS-4A** models are user configurable, high speed, network print servers that support up to four printers. The **PS-4A** has four parallel ports, the **PS-4C** will have four high speed serial ports, and the **PS-4E** has two parallel and two high speed serial ports. The BayTech **LaserShare Network PS-MIO** is a network print server card which installs into the MIO slot of the HP LaserJet Series IIISi, Series 4, and Series 4SI laser printers. Each BayTech print server is compatible with Novell NetWare 3.XX using normal NetWare commands and utilities (i.e., PCONSOLE, CAPTURE, and NPRINT). You may use an Ethernet 10BASE2 (thin coax) or 10BASE-T (twisted pair) network interface. The BayTech print server services up to 32 print queues distributed on as many as 32 file servers.

Tran-x high speed parallel/serial converter products allow you to extend parallel cables to 1000+ feet and allow your network server, graphics workstation, or PC to send/receive data at speeds up to 46,000 characters per second. You can use the Tran-x Series with BayTech Model 24SII, LaserShare, or network print servers for the fastest long distance peripheral sharing solution available anywhere. Modular cabling provides simplicity in connections between remote devices. **Tran-x LPT-460** card plugs directly into your PC expansion slot. **Tran-x PS-02** connects to your PC's parallel port. **Tran-x SP-01** connects to the Centronics connector of a parallel printer. **Tran-x PS-02** connects to the DB-25 parallel port of the BayTech 700 Series Print Master or 800 Series Print Master II peripheral sharing units.

"500H" Series, Model 24SII DAC, and Model 60 DAC Data Acquisition and Control units connect between one host computer and multiple peripheral devices. These models are often used in industrial process-control environments (e.g., for allowing control of multiple numerical or assembly-line machines), in exchanging data between point-of-sale devices, or for operating a number of laboratory instruments or business machines from a central computer. They are especially effective in adapting small low-cost personal computers to these applications. Each unit features six modes of operation which may be easily configured to your application. The **500H** series models are available with either 5 or 9 ports. The **Model 24SII DAC** unit is expandable from 4 to 24 ports and the **Model 60 DAC** unit is expandable from 4 to 60 ports in 4-port modular increments.

Telplex Models TX102, TX104 and TX108 are asynchronous statistical multiplexers which multiplex and demultiplex two, four, or eight communications channels over a single channel. This single channel is typically a telephone line or cable. The **TX20** and **TX60** will multiplex and demultiplex up to twenty and sixty channels respectively. Programmable features include serial port parameters (baud rate, word size, etc.), data flow control, user-programmable strings to be sent to an external modem, and remote diagnostics and configuration capability. These units must be purchased in pairs.

Telplex Model TX104M is an asynchronous statistical multiplexer with built-in modem. Four individual communications channels are multiplexed into a single dial-up or leased telephone line, cutting phone line costs to a minimum. The TX104M features a V.22 bis internal modem which provides reliable communication at speeds up to 4800 bps. With V.42 bis protocol, the TX104M provides error correction and Classes 2-4 data compression. Compatible with most computers, printers, or peripherals, the TX104M ensures rapid throughput, and offers a variety of user-programmable features in order to meet your specific application requirements.

Telplex Model TX108M is an asynchronous statistical multiplexer with built-in modem. Eight individual communications channels are multiplexed into a single dial-up or leased telephone line, cutting phone line costs to a minimum. The TX108M features a V.32 internal modem with MNP Class-4, which provides reliable communication at speeds up to 9600 bps.

Telplex Model BX9600 is an external asynchronous 9600 bps modem. The BX9600 features V.32 full duplex communication, automatic or manual dialing and answering, call progress detection of dial tones and busy signals, pulse or tone dialing, and a variety of other convenient features. The BX9600 interfaces easily to statistical multiplexers and other peripheral sharing devices to allow multiple users to share the modem. And its MNP Class 4 error correction ensures that the BX9600 provides accurate transmission.

The **BX2448** is a V.22 bis external modem which uses dial-up or leased telephone lines and comes equipped with many advantageous features, such as MNP Class 5 data compression, which enables data transmission at speeds to 4800 bps and, MNP Classes 2 - 4 error correction. A wide selection of user-programmable features allows you to customize the modem to your own individual application situation.

500 SERIES MULTIPOINT CONTROLLERS

Included in the **500 Series** line of multipoint controllers are units intended for the following applications:

Port Expansion (A-Series): Allows a single serial port on a computer to individually access up to 17 peripheral devices with full duplex communication.

Single Port Contention (DQ-Series): Allows up to 17 terminals to contend for a single port on a computer system.

Multiple Port Contention (B-Series): Allows either 6, 8 or 12 terminals to contend for either 3, 4 or 6 computer ports respectively.

Networking (F-Series): Networks either 5 or 9 ports together, i.e., allows any port to connect to any other port on the multipoint controller. These also have host port control which allows a host computer system to make and/or break any connection between two ports on the multipoint controller.

Broadcasting (G-Series): Will simultaneously broadcast whatever data is received on the host port out to either 4 or 8 peripheral devices while sending data from a single selected peripheral device back to the host device. This unit is also capable of operating in a port expansion mode such as the **A-Series**.

Auto T-Switch (T-Series): Allows a group of up to 6 terminals to switch between two computer systems.

NOTE: All ports on the **500 Series** are standard with EIA-232 ports. EIA-422 and Current Loop ports are optionally available.

If you have questions concerning any of BayTech's products, please feel free to call a BayTech Applications Engineer at either (800)523-2702 or (228)467-8231.

NOTES:

NOTES: