

# OWNER'S MANUAL

---

## V93A DAC: 14.4k bps HOST COMMUNICATION MODEM MODULE FOR BAYTECH M SERIES DAC MODELS

BayTech Manual Publication #U140E116-02

## FCC REQUIREMENTS FOR THE V93A HOST COMMUNICATION MODEM MODULE

1. The Federal Communications Commission (FCC) has established rules which permit this device to be directly connected to the telephone network. Standardized jacks are used for these connections. This equipment should not be used on party lines or coin lines.
2. If this device is malfunctioning, it may also be causing harm to the telephone network; this device should be disconnected until the source of the problem can be determined and until repair has been made. If this is not done, the telephone company may temporarily disconnect service.
3. The telephone company may make changes in its technical operations and procedures; if such changes affect the compatibility or use of this device, the telephone company is required to give adequate notice of the changes. You will be advised of your right to file a complaint with the FCC.
4. If the telephone company requests information on what equipment is connected to their lines, inform them of:
  - a. The telephone number this unit is connected to
  - b. The ringer equivalence number
  - c. The USOC jack required: RJ-11
  - d. The FCC Registration Number

Items 'b' and 'd' are indicated on the label.

The ringer equivalence number (REN) is used to determine how many devices can be connected to your telephone line. In most

areas, the sum of the RENs of all devices on any one line should not exceed five (5.0). If too many devices are attached, they may not ring properly.

In the event of equipment malfunction, all repairs should be performed by our Company or an authorized agent. It is the responsibility of users requiring service to report the need for service to our Company or to one of our authorized agents. Service can be obtained at:

Bay Technical Associates, Inc.  
P.O. Box 387, 200 N. Second Street  
Bay St. Louis, MS 39520 U.S.A.  
Phone: **800-523-2702** or  
228-467-8231  
Fax: 228-467-4551  
Web Site: [www.baytechdcd.com](http://www.baytechdcd.com)

# TABLE OF CONTENTS

<b>1</b>	<b>GENERAL INFORMATION.....</b>	<b>5</b>
<b>2</b>	<b>SPECIFICATIONS .....</b>	<b>6</b>
<b>3</b>	<b>SOFTWARE UTILITY DISKETTE .....</b>	<b>6</b>
<b>4</b>	<b>CABLES &amp; ADAPTERS .....</b>	<b>7</b>
<b>4.1</b>	EIA-232 CONNECTION.....	7
<b>4.2</b>	MODEM CONNECTION.....	8
<b>5</b>	<b>OPERATION.....</b>	<b>9</b>
<b>5.1</b>	LOGIN PASSWORD.....	9
<b>5.2</b>	PORT SELECTION MENU .....	10
<b>5.3</b>	MANUAL MODE - .....	11
<b>5.4</b>	EXIT .....	13
<b>5.5</b>	UNIT RESET.....	13
<b>5.6</b>	LOGOUT .....	14
<b>6</b>	<b>CONFIGURATION .....</b>	<b>14</b>
<b>6.1</b>	STATUS .....	15
<b>6.2</b>	SERIAL PORT CONFIGURATION.....	15
<b>6.3</b>	PORT DEVICE NAME.....	16
<b>6.4</b>	PORT SELECT CODE.....	17
<b>6.5</b>	ATTENTION CHARACTER.....	18
<b>6.6</b>	DISCONNECT TIME GUARD.....	18
<b>6.7</b>	LOGIN PASSWORD.....	19
<b>6.8</b>	LOCAL MODEM SETUP.....	19
<b>6.9</b>	EXIT .....	20
<b>6.10</b>	ECHO MODE.....	20
<b>6.11</b>	RING DETECT RESET .....	21
<b>6.12</b>	MODEM LED INDICATORS .....	21
<b>7</b>	<b>V93A EPROM UPGRADE.....</b>	<b>22</b>
<b>8</b>	<b>V93A MECHANICAL LAYOUT .....</b>	<b>23</b>
<b>9</b>	<b>INDEX.....</b>	<b>24</b>

# 1 GENERAL INFORMATION

The V93A Host Communication Modem Module is the remote user interface to the BayTech M Series DAC (Data Acquisition and Control) units. This module features a V.32bis/V.42bis internal modem and allows a remote host terminal to connect and issue specific configuration or data commands to the various I/O modules or the M Series DAC unit main board. Multiple V93A modules can be installed in a M Series chassis allowing I/O modules to send data to specific V93A modules. Please see the M Series DAC Owner's Manual for more information on the available types of I/O modules.

**IMPORTANT:** The first module slot of the M Series DAC base unit must be occupied by a host module.

## **2 SPECIFICATIONS**

**INTERFACE:** Dial-up telephone line

**MODULATION:** V.32bis (14,400 bps) or V.32 (9600 bps)

**COMPRESSION:** V.42bis, MNP5

**CONNECTORS:** 2 x 4-pin modular

**MODULE LEADS:** *TD* (Transmit Data), *RD* (Receive Data), *CD* (Carrier Detect), *MR* (Modem Ready), and *CX* (Connection) status LEDs.

**TRANSMIT LEVEL:** -10 dBm (dial-up)

**RECEIVER SENSITIVITY:** -45 dBm

**DIMENSIONS:** 6"h x 4.5"w.

### **FACTORY POWER-UP DEFAULT CONFIGURATIONS:**

**Port Select Code:** \$BT

**Password:** BTA, disabled

### **USER-PROGRAMMABLE CONFIGURATIONS:**

Easy to configure using on-screen menu. Choices are saved in non-volatile memory to become the new power-up default configuration.

## **3 SOFTWARE UTILITY DISKETTE**

**IMPORTANT:** Copy the BayTech original diskette onto a blank diskette and store the original in a safe place.

BayTech provides utility software for DOS compatible PCs to assist you in configuring your M-Series DAC unit. This diskette contains several programs, however the only programs that will be used is TERM.EXE and README.RDM. TERM.EXE is a terminal emulation program for DOS compatible PCs used to configure the various features of the unit.

Please review the README.RDM file to obtain instructions for TERM.EXE. To view the README.RDM file on your screen, first insert the diskette into your PC's disk drive and then enter the command **TYPE README.RDM** from your disk drive prompt. To print this file, enter the command **COPY README.RDM LPT1:** from your disk drive prompt

## **4 CABLES & ADAPTERS**

The V93A modem has two modular connectors for device selection and configuration. One connector is for connection to a dial-up line. The other connector is used to communicate with an EIA-232 port.

### **4.1 EIA-232 CONNECTION**

Connect the eight pin modular cable(RJ-45) to the port labeled EIA-232 on the V93A. Connect the DB9 adapter to the serial port of your PC or terminal and then connect the other end of the cable to the RJ-45 side of the adapter. Use adapter BayTech part number 9FRJ45PC-3 and cable, BayTech part number RJ08X007 that come with the RPC.

*Figure 1* shows the required adapter for a PC with a DB-25 connector. Use a crossed RJ-45 cable to connect these adapters to the EIA-232 port.

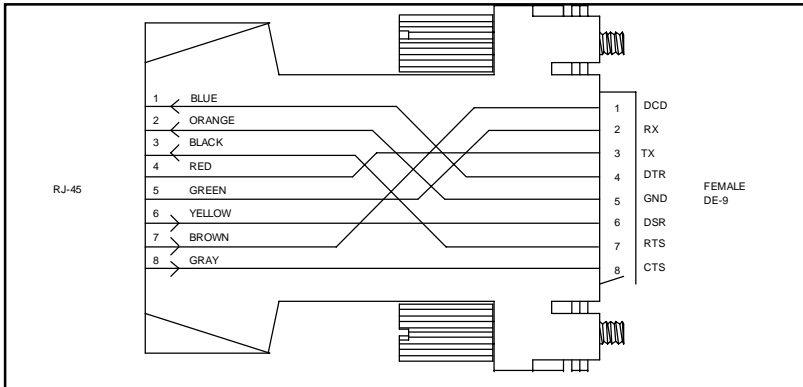

**Figure 1: PC, PS/2 Computer/Terminal Adapter  
BayTech Part No. 9FRJ45PC-3**

Figure 2 shows the required adapter for a PC or terminal with a DB-25 connector. Use a crossed RJ-45 cable to connect these adapters to the EIA-232 port.

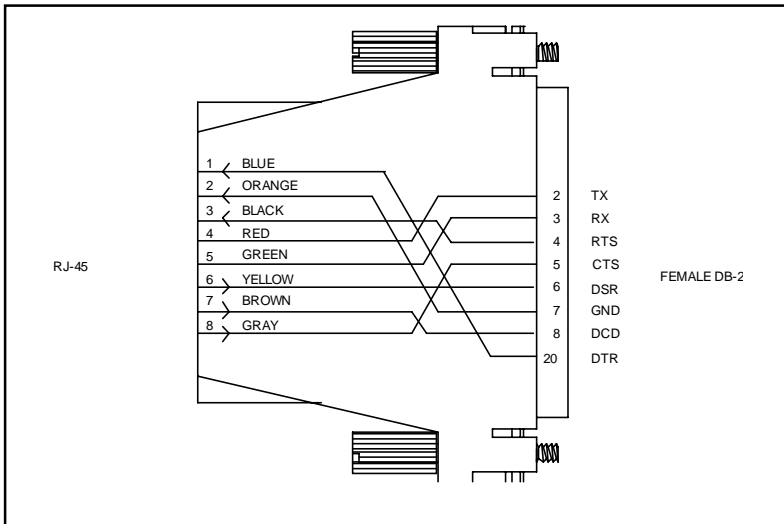

**Figure 2: PC, PS/2 Computer/Terminal Adapter  
BayTech Part No. 25FRJ45PC-3**

**IMPORTANT:** When modular connectors are used as shown in *Figures 1 - 2* above with RJ-45 connectors, crossed RJ-45 cables are required. See the cable diagram that follows.

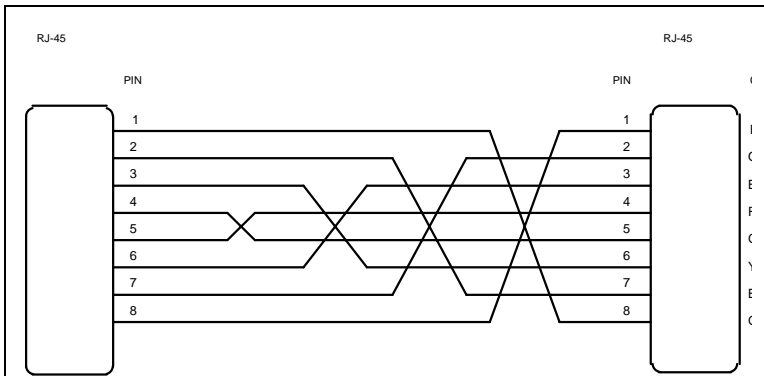

**Figure 3:** RJ-45 Cable  
BayTech Part No. RJ08X010 (10 feet)

## 4.2 MODEM CONNECTION

Connect the phone line to the RJ-11 connector on the V93A with a RJ-11 cable.

## 5 OPERATION

a. You are ready to perform commands when a terminal or PC is communicating with:

- (1) the V93A's EIA-232 port.
- (2) a remote modem is communicating with the V93A's modem.

b. If you are using a PC, you can communicate with the V93A by using a terminal emulation program or by using a software communications program that emulates a terminal. BayTech supplies an utility diskette which includes TERM.EXE, a terminal emulation program, to put your PC into terminal emulation mode. Popular communication software packages

such as PROCOMM PLUS(R) by Data Storm Technologies, also provide terminal emulation capabilities and allow for communications with the V93A.

c. If configuring the V93A from the EIA-232 port, configure the host terminal's serial parameters to match those of the V93A. From the factory, the V93A is set at 9600 baud, 8 data bits, 1 stop bit no parity and XON/XOFF disabled.

## 5.1 LOGIN PASSWORD

Once the V93A has been connected to the phone line and configured for the desired parameters, a remote host computer can make a connection to the V93A modem over a dial line and perform data acquisition and control functions with the various M Series I/O modules. The V93A will send a message similar the following when a remote host computer establishes a connection:

```
M-Series V93A DAC Host
Unit 2 Module 1
REV. 4.XX Copyright (c) 1995-1997
Bay Technical Associates
```

```
To login, enter password
Login: BTA (default)
```

You will be prompted to type in the desired password followed by <ENTER> when a connection to the V93A modem is first made. You are given three tries to type in the correct password before the modem hangs up. Type the appropriate password (Default is BTA). The V93A will respond with:

```
Login successful
Port Select Code: $BT
Attnetion Character: ;
```

Among the functions you can perform are data commands/port selection and configuration. Configuration commands are used to program the features of the various I/O modules and the data commands are typically used to request stored data received from an I/O module. Data commands

are also used to instruct certain I/O modules to perform a specific task (e.g., energize or de-energize a relay).

The configuration menu is invoked by selecting configure(C) from the port selection menu. The supported configuration and data commands for a specific I/O module are described in the documentation for that module.

## 5.2 PORT SELECTION MENU

To activate the port selection menu, type **5 or more ;;;; (default)** in a row and a menu similar to the following will appear.

```

.      M-Series V93A DAC Host
      Unit 1 Module 2
      REV. 4.00 Copyright(c) 1995-1997
      Bay Technical Associates

      Device A      (2,1).....1
      Device B      (2,2).....2
      Device C      (2,3).....3
      Device D      (2,4).....4
      Configure.....C
      Manual Mode.....M
      Exit.....X
      Unit Reset.....R
      Logout.....T
      Enter Request :
```

The device names in the menu correspond to the device names assigned to the serial ports installed in the unit. To select a particular device simply enter the number of the device then hit return. *Refer to section 16.4 of the M-Series DAC owners manual for configuration of device names.*

The other items in the menu provide various functions described below:

**Configure** - Allows users enter into the configuration mode for any installed modules or for the base unit. See Section 6 CONFIGURATION for details to configure the unit.

## 5.3 MANUAL MODE -

Manual Mode allows users to manually select a module and/or port. The “*Manual Mode*” selection for the V93A menu is used to make a module level connection which is used for sending commands to the module. The “*Manual Mode*” is used to make a connection to a module such as the Control Relay Module, A-to-D Module, Event Counter Module, main board, etc. Use the “*Manual Mode*” for module connections other than a Serial I/O module unless you want to operate a Serial I/O module in the Command Mode of operation. The “*Manual Mode*” selection **should not** be used for configuration.

By responding to the *Enter Request:* message at the end of the V93A menu with “M” you receive a response similar to the following:

```
Device A      (2,1)..... 1
Device B      (2,2)..... 2
Device C      (2,3)..... 3
Device D      (2,4)..... 4
Device A      (3,1)..... 5
Device B      (3,2)..... 6
Device C      (3,3)..... 7
Device D      (3,4)..... 8
Configure .....
```

```
Manual Mode ..... M
Exit..... X
Unit Reset ..... R
Logout ..... T
```

Enter Request: M

Enter Module number: 2

Enter Port number (<CR> for none): 3

By entering “2” at the *Enter Module number* and entering “3” at the *Enter Port number*, the user has selected module number 2 and port number 3. Verify the connection by insuring that the red LED of Port 3, Module 2 on the front panel of the M-Series DAC base unit has been selected.

## 5.4 EXIT

By responding to the *Enter Request:* message in the V93A Status & Diagnostics Menu with “X” (Exit), you will exit the V93A Status & Diagnostics Menu. The V93A host module will respond with a menu that is similar to the following: .1 >X

## 5.5 UNIT RESET

Users can instruct the M-Series DAC with the V93A module, to “reset” by using the *Menu Selection Method* to reset the unit. The Unit Reset command does not affect any saved configuration parameters that have been changed from the default values.

By responding to the *Enter Request:* message at the end of the menu with “R”(Unit Reset), you will reset the M-Series unit.

```
Device A      (2,1)..... 1
Device B      (2,2)..... 2
Device C      (2,3)..... 3
Device D      (2,4)..... 4
Device A      (3,1)..... 5
Device B      (3,2)..... 6
Device C      (3,3)..... 7
Device D      (3,4)..... 8
Configure ..... C
Manual Mode ..... M
Exit.....X
Unit Reset ..... R
Logout ..... T
```

Enter Request: R

The M-Series DAC unit has been reset.

**Important:** The Unit Reset command will terminate communications with connected equipment to the M-Series DAC. You must re-establish communications with the M-Series DAC system after the unit has been reset. The Menu is invoked by sending the **Attention Character(default ;;;;)** to the V93A host module five times. The V93A will respond with a menu similar to the following, if two Serial I/O modules are installed.

## 5.6 LOGOUT

By responding to the *Enter Request:* message in the V93A Main Menu with “T” (Logout), you will take you out of menu mode. If you have a modem connection it will terminate that connection. The V93A host module will respond with a message similar to the following:

```
Device A      (2,1)..... 1
Device B      (2,2)..... 2
Device C      (2,3)..... 3
Device D      (2,4)..... 4
Device A      (3,1)..... 5
Device B      (3,2)..... 6
Device C      (3,3)..... 7
Device D      (3,4)..... 8

Configure ..... C
Manual Mode.... M
Exit.....X
Unit Reset ..... R
Logout ..... T
Enter Request:
```

To return to the menu after making a connection, simply type 5 or more ‘;’ semicolons(default).

**NOTE:** Menu selection is case sensitive.

## 6 CONFIGURATION

To access configuration, bring up the menu and select option ‘C’. Select the module number associated with the V93A. For example, if the V93A is installed in module slot 4, select the number from the menu that is associated with Module 4. The menu below will appear.

```
Status.....1
Serial Port Configuration.....2
Port Device Name.....3
Port Select Code.....4
Attention Character.....5
Disconnect Timeguard.....6
Login Password.....7
Local Modem Setup.....8
Exit.....X
Enter Request :
```

## 6.1 STATUS

By responding to the menu with a "1" (Status), you can review the current configuration of the V93A. Below is the default status.

```
Installed Modules :1,2
Port Select Code is.....$BT
Attention Character is.....;
Disconnect Time Guard is.....Disabled
Local Modem Setup :
Rings to Auto-Answer.....2
Modem Connectivity Time-out is.....Disabled
Login Setup:
Login Password is.....BTA
```

Strike any Key to Continue

Port	Device Name	Baud Rate	Word Size	Stop Bits	Parity	Xon/Xmit	Xoff/Recv
1	Host EIA-232	9600	8	1	None	Off	Off
2	Host Modem	57.6k	8	1	None	Off	Off

Strike any Key to Continue

## 6.2 SERIAL PORT CONFIGURATION

By responding with "2" (Serial Port Configuration), you can change serial configuration for the EIA-232 port on the V93A. The V93A will then respond with:

Enter Host Device Number (1-2): 1

Module 1 Serial Port Configuration :

Port	Device Name	Baud Rate	Word Size	Stop Bits	Parity	Xon/Xmit	Xoff/Recv
1	Device A	9600	8	1	None	Off	Off

```
Exit/Save.....1   Set Stop Bits.....4
Set Baud Rate..2   Set Parity.....5
Set Word Size..3   Set Xon/Xoff.....6
```

Enter Request :

You can now reconfigure the V93A EIA-232 port by sending the appropriate option (1 to 6) from the menu. For example, to change the baud rate to 115.2K, send "2" (Set Baud Rate). The V93A will respond with:

1 For 300

```

2 For 600
3 For 1200
4 For 2400
5 For 4800
6 For 9600
7 For 19200
8 For 38400
9 For 57.6K
A For 76.8K
B For 115.2K
Enter Request :

```

Send "B" for 115.2K baud rate. The V93A will respond with the reconfigured status of the port as follows:

Module 2 Serial Port Configuration :

Port	Device Name	Baud Rate	Word Size	Stop Bits	Parity	Xon/Xmit	Xoff/Recv
1	Device A	9600	8	1	None	Off	Off

```

Exit/Save.....1 Set Stop Bits.....4
Set Baud Rate..2 Set Parity.....5
Set Word Size..3 Set Xon/Xoff.....6

```

Enter Request :

You can now select other options from the menu. If there are no other changes, send "1" (Exit/Save) and the V93A will respond with:

Save Changes Permanently ? (Y/N) :

If you type "Y", the new configuration for the selected port is stored permanently in non-volatile memory until. If you type "N" the V93A will return to the main configuration menu.

**NOTE:** If you are configuring the V93A from the EIA-232 port, the V93A will respond with:

```

Change Device to NEW Configuration
Before Answering This Request.

```

**CAUTION:** This message reminds you to change the serial port configuration of the host device now. If they do not match, the V93A will be unable to interpret the next command. If this happens, cycle power on the M-Series DAC and reconfigure the unit.

## 6.3 PORT DEVICE NAME

By responding with "3" (Port Device Name), you can change the Port Device Name. The V93A module will respond with a menu similar to the following:

Module 1 Device Name :

Port	Device Name	Baud Rate	Word Size	Stop Bits	Parity	Xon/Xmit	Xoff/Recv
1	Device D	9600	8	1	None	Off	Off

Enter Port Device Name (Max. 16 characters):  
 or ENTER for no change .....

Enter the desired Port Device Name up to 16 characters. For example, if you type "PORT 4" followed by <ENTER>, the module will respond with:

Module 1 Device Name :

Port	Device Name	Baud Rate	Word Size	Stop Bits	Parity	Xon/Xmit	Xoff/Recv
1	Port 4	9600	8	1	None	Off	Off

Enter Port Device Name (Max. 16 characters):  
 or ENTER for no change .....

If the Port Device Name is satisfactory, type <ENTER>. The V93A will return to the main configuration menu.

**NOTE:** If the V93A Connect Port ID Echo feature is programmed for Use Device Name, the message sent to the host device when the host selects a V74/V75 peripheral port will be the Device Name shown in the menu above.

## 6.4 PORT SELECT CODE

By responding with "4" (Port Select Code), you can change the Port Select Code to any ASCII character string from 1 to 8 characters. The V93A will respond with:

Port Select Code is.....\$BT

Enter Port Select Code (Max. 8 characters):  
 or ENTER for no change.....:

Type the desired Port Select Code followed by <ENTER>. For example, if you type #PORT followed by <ENTER>, the V93A will respond with:

```
Port Select Code is.....#PORT
Enter Port Select Code (Max. 8 characters):
or ENTER for no change.....:
```

If no additional change is desired, type "ENTER". The V93A will store the new Port Select Code permanently into non-volatile memory and return to the main configuration menu.

## 6.5 ATTENTION CHARACTER

By responding with "5" (Attention Character), you can change the Attention Character to be any ASCII character. The V93A will respond with:

```
Attention Character is..... ;
Change It ? (Y/N) :
```

Type "Y" to change the Attention Character. The V93A will respond with:

```
Enter Attention Character :
```

Type the desired Attention Character. For example, if you type "%", the V93A will respond with

```
Attention Character is..... %
Change It ? (Y/N) :
```

Type "N" if no additional change is desired. The V93A will store the new Attention Character into non-volatile memory and return to the main configuration menu.

## 6.6 DISCONNECT TIME GUARD

By responding with "6" (Disconnect Time Guard), you can determine if you want a one second delay. The V93A will respond with:

```
Disconnect Time Guard is.....Enabled
Change It? (Y/N):N
```

Type "Y", to toggle the existing state of Disconnect Time Guard or "N" for no change. The V93A will store the selected state of the Disconnect Time Guard into non-volatile memory and return to the main configuration menu.

## 6.7 LOGIN PASSWORD

By responding with "7" (Login Setup), you can change the Login Password. The V93A will respond with:

```
Login Password Is.....BTA
Change It: (Y/N):
```

Type "Y" to enter the new password up to 8 ASCII characters followed by <ENTER>. For example, if you want to change the Login Password to LOGIN, type "LOGIN" at the prompt. The V93A will respond with:

```
Enter New Password( 1 - 8 char., CR to end):
```

If the Login Password is correct, type "N". The V93A will store the new Login Password into non-volatile memory and return to the main configuration menu.

## 6.8 LOCAL MODEM SETUP

By responding with "8" (Local Modem Setup), you can change the Rings to Answer and the Connectivity Time-out. The V93A will respond with:

```
Local Modem Setup:
Rings to Answer.....1
Connectivity Time-out.....2
Exit.....X
Enter Request :
```

Type the number corresponding to your desired choice. For example, if you type "1" (Rings to Answer), the V93A will respond with:

```
Rings to Auto-Answer.....1
Change It ? (Y/N) :
```

Type "Y" to change the Number Rings to Auto-Answer setting. The V93A will respond:

Enter Number of Rings to Auto-Answer (1 to 4) :

The V93A will store the Number of Rings to Auto-Answer in non-volatile memory and return to the main configuration menu.

By responding to the message in the Local Modem Setup menu with "2" Connectivity Time-out: The V93A will respond with:

```
Enter Request : 2
```

```
Modem Connectivity Time-out is.....5 minutes
```

```
Change It ? (Y/N) :
```

This time-out can be programmed from 5 to 255 minutes, or 0 (=disable). The timer is started when the modem goes off-hook (DCD goes high), and the modem will return to "on hook" after the time-out has expired. The factory default is 0 (disabled).

## 6.9 EXIT

By responding with "X" (Exit), you will exit configuration mode. At this point, the V93A is awaiting a command from the host device (i.e., Attention Character sent five times).

## 6.10 ECHO MODE

The V93A can be placed into *echo mode* by sending seven semicolons (;) in succession. While in echo mode, the V93A will echo all characters received by the connected device back to that device. Echo mode is terminated by placing an I/O module into command mode (**\$BTm<cr>** where m is the desired module number. Echo Mode would be used only when the ASCII string method of port selection is used. If the Menu Mode(Attention character method) of port selection is used the Echo Mode is not required.

## 6.11 RING DETECT RESET

The V93A has a Ring Detect Reset feature that will automatically cycle power on the M Series unit if an incoming call is detected and not answered within seventy seconds. The Ring Detect Reset feature is enabled by connecting a straight 2-wire or 4-wire cable between the auxiliary 4-pin modular connector on the V93A and the *DIAL* service modem port on the M Series chassis.

## 6.12 MODEM LED INDICATORS

The V93A has five LEDs on the rear panel that indicate the modem status: *TD*, *RD*, *CD*, *MR*, and *CX*. These LEDs are described below.

LED	Description
TD	Transmit Data: Indicates the modem is transmitting data.
RD	Receive Data: Indicates the modem is receiving data.
CD	Carrier Detect: Indicates a valid carrier tone has been detected.
MR	Modem Ready: Indicates the modem is ready to communicate.
CX	Connection: Indicates the V93A has a connection to the main board, to a module, or to an individual channel or port.

## 7 V93A EPROM UPGRADE

You will receive one EPROM (chip with label) for each module to be upgraded.

The materials you will need to supply are:

Flat blade screwdriver

IC DIP extractor or a pair of curved needle-nose pliers

1. **IMPORTANT:** Remove power from the unit by depressing the power switch on the front of the unit to OFF. Also remove power cord from the AC outlet.
2. Remove the appropriate module by loosening the 2 straight slot screws that attach the connector board I/O module to the chassis and then pulling the module out.
3. Refer to *Appendix B* (V93A Mechanical Layout) and locate socket *U2*. Remove existing EPROM from socket *U2* with IC extractor or needle-nose pliers. Gradually loosen each side of the chip, alternating pliers from side to side, so as not to bend chip pins. Pull loosened EPROM all the way out.
4. Install the new EPROM into socket *U2*. The EPROM is notched; the notch on the EPROM should line up with the notch on the socket. Be careful not to bend any of the pins. Make sure none of the pins miss their sockets. If the socket has more holes than chip pins, the pins should line up starting at the edge of the board.
5. Re-install the V93A and apply power to the unit. The upgrade is now complete. Before you begin operations, check the configuration status to make certain it matches your application. See *Section 5* for complete instructions.

# 8 V93A MECHANICAL LAYOUT

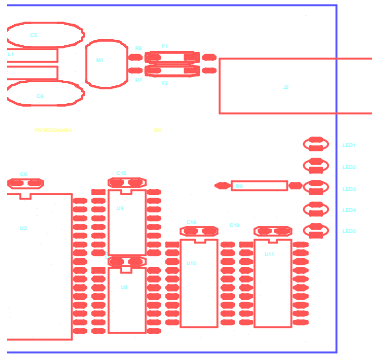

## 9 INDEX

### A,B \_\_\_\_\_

ASCII 2-4, 10, 11

### C \_\_\_\_\_

Cabling 3

Cascade 1

Cascading application 5, 7, 8

Case sensitive 9

Channel 7

Commands 1, 3-5

Configuration 1-5, 7-13, 15

Connectors 2, 3

Control panel 13

### D \_\_\_\_\_

DAC 1, 4, 8, 9, 13

Data commands 1, 3-5

De-energize 4

Default 2-6, 8

Dimensions 2

Disable 1, 3, 4, 8-13

Disconnect 5, 6, 8

### E,F \_\_\_\_\_

Echo mode 6

EIA-232 8

Enable 1, 3, 4, 8-13

Energize 4

Enter 4, 7-12

Eprom upgrade 14

Front panel 7, 13

## **G,H**\_\_\_\_\_

Hex 5

Host module 1, 6, 10

## **I**\_\_\_\_\_

IC 14

Identification block 8

Inactivity timeout 1-4, 8, 9, 12, 13

Interface 1, 2

## **J,K,L**\_\_\_\_\_

LCD display 13

LED 7

## **M**\_\_\_\_\_

M Series 1, 3-9, 13

Main configuration menu 8-12

Main unit 1

Memory module 8

Menu 2, 3, 5, 8-13

Mode 3, 5-9, 12

Modular connectors 3

Module number 5-7, 13

## **N,O,P**\_\_\_\_\_

Non-verbose mode 5  
Non-volatile memory 2, 10, 12  
Operation 3, 4  
Optional 3, 5  
Parity 8  
Password 1-4, 6-11  
Port select code 1-3, 5-10, 12, 13  
Power cord 14  
Power switch 14

## **Q,R,S**\_\_\_\_\_

Reset 3, 6, 7  
Reset command 6  
Ring detect reset 3, 7  
Select code 1-3, 5-10, 12, 13  
SELECT key 13  
Select sequence 3, 5  
Service modem 3, 7  
Service port 3, 6-8, 10  
Specifications 2  
Start 11  
Status 2, 7-9, 11, 13, 15  
Switch 14

## **T**\_\_\_\_\_

Terminal 1, 3, 6-8  
Terminating character 5, 6

## **U,V**\_\_\_\_\_

Unit number 5, 7, 9  
Upgrade 14, 15  
User-programmable 2, 3

Verbose mode 5

**W,X,Y,Z**\_\_\_\_\_

Word size 8